

Silicon NPN Power Transistors

2SD1879

DESCRIPTION

- With TO-3PML package
- High speed
- High breakdown voltage
- High reliability
- Built in damper diode

APPLICATIONS

- Color TV horizontal deflection output
- Color display horizontal deflection output.

PINNING

PIN	DESCRIPTION
1	Base
2	Collector
3	Emitter

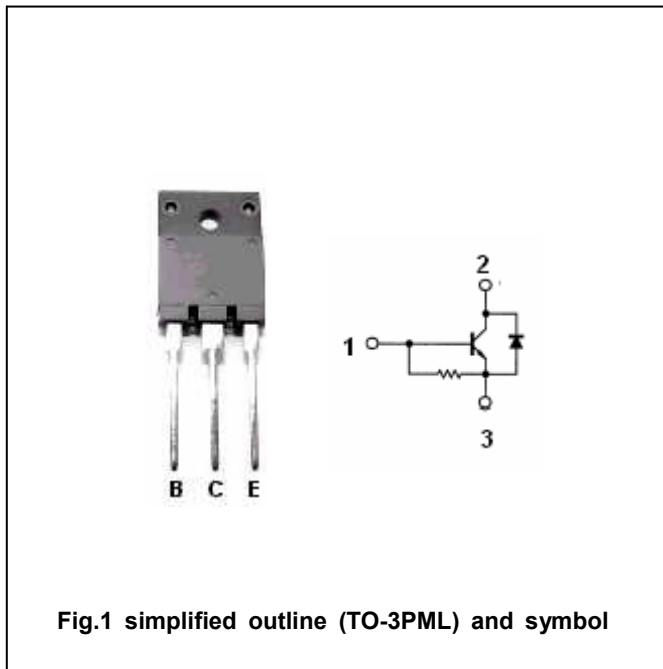

Fig.1 simplified outline (TO-3PML) and symbol

Absolute maximum ratings(Ta=□)

SYMBOL	PARAMETER	CONDITIONS	VALUE	UNIT
V _{CBO}	Collector-base voltage	Open emitter	1500	V
V _{CEO}	Collector-emitter voltage	Open base	800	V
V _{EBO}	Emitter-base voltage	Open collector	6	V
I _C	Collector current		6	A
I _{CM}	Collector current-peak		20	A
P _C	Collector power dissipation	T _C =25□	60	W
			3	
T _j	Junction temperature		150	□
T _{stg}	Storage temperature		-55~150	□

Silicon NPN Power Transistors

2SD1879

CHARACTERISTICS

T_j=25°C unless otherwise specified

SYMBOL	PARAMETER	CONDITIONS	MIN	TYP.	MAX	UNIT
V _{CEO(SUS)}	Collector-emitter sustaining voltage	I _C =100mA ; I _B =0	800			V
V _{CEsat}	Collector-emitter saturation voltage	I _C =5A ; I _B =1A			5	V
V _{BEsat}	Base-emitter saturation voltage	I _C =5A ; I _B =1A			1.5	V
I _{CBO}	Collector cut-off current	V _{CB} =800V ; I _E =0			10	μA
I _{EBO}	Emitter cut-off current	V _{EB} =4V ; I _C =0	40		130	mA
I _{CES}	Collector cut-off current	V _{CE} =1500V			1.0	mA
h _{FE-1}	DC current gain	I _C =1A ; V _{CE} =5V	8			
h _{FE-2}	DC current gain	I _C =5A ; V _{CE} =5V	5		10	
V _F	Diode forward voltage	I _{EC} =6A ; I _B =0			2	V
t _f	Fall time	I _C =4A; R _L =50Ω; V _{CC} =200V I _{B1} =0.8A; - I _{B2} =1.6A		0.1	0.3	μs

Silicon NPN Power Transistors

2SD1879

PACKAGE OUTLINE

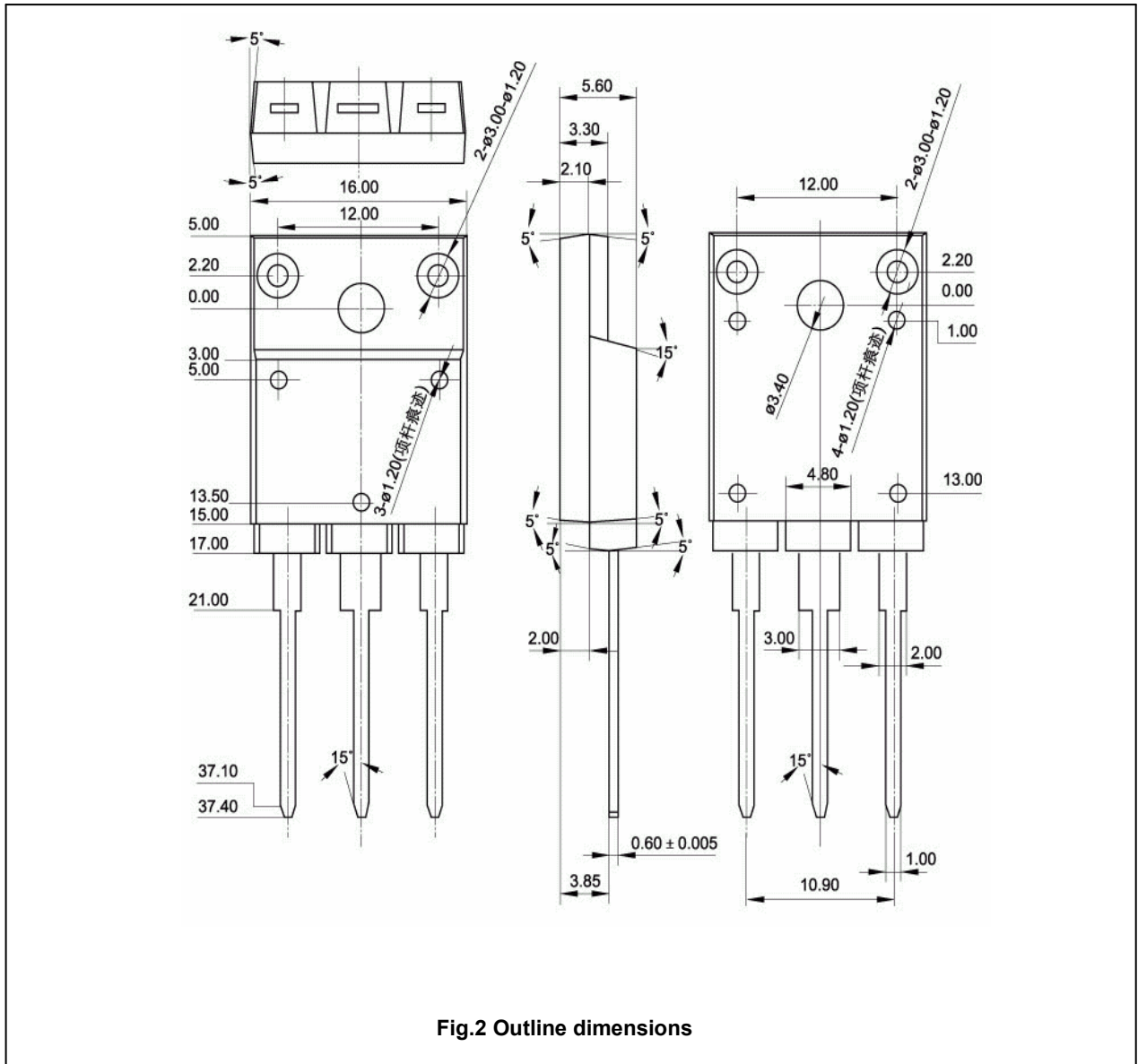

Fig.2 Outline dimensions

Silicon NPN Power Transistors

2SD1879

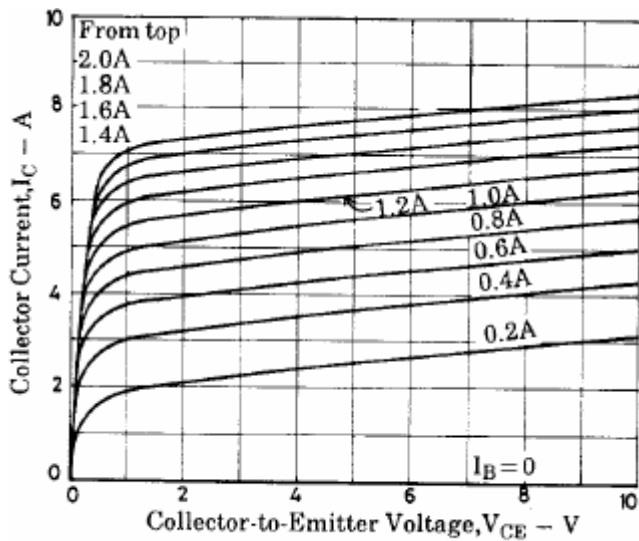

Fig.3 Static Characteristic

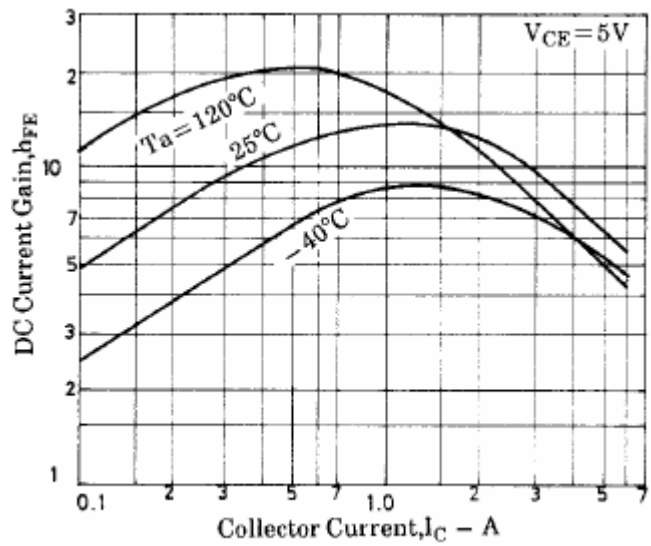

Fig.4 DC current Gain

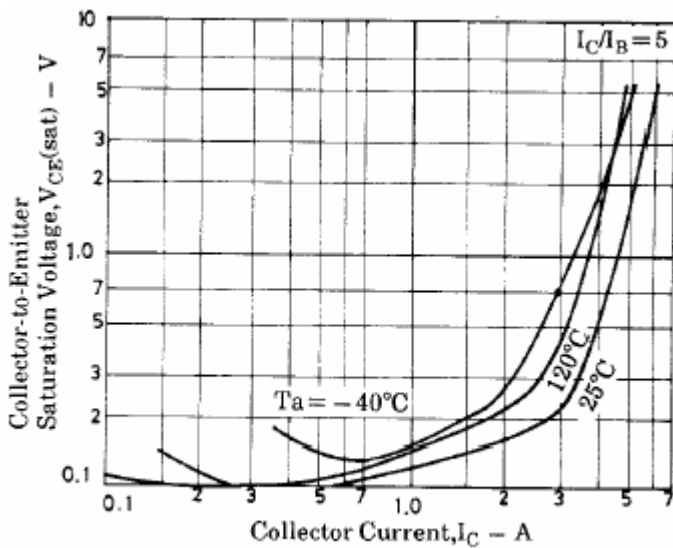

Fig.5 Collector-Emitter Saturation Voltage

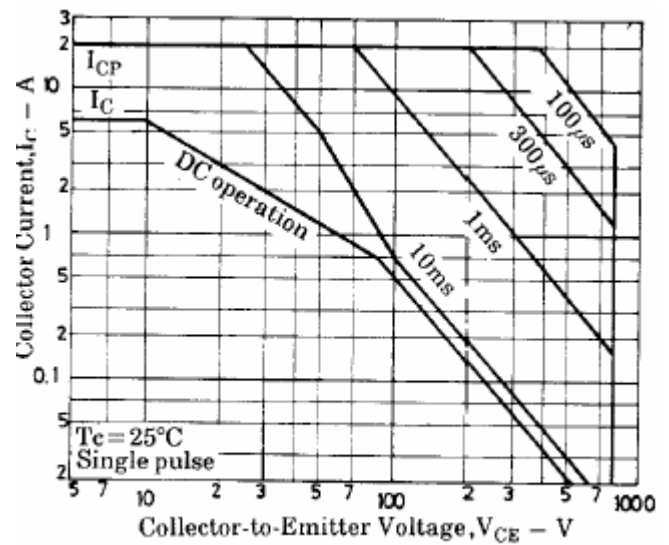

Fig.6 Safe Operating Area

This datasheet has been downloaded from:

www.DatasheetCatalog.com

Datasheets for electronic components.