



# TECHNICAL GUIDE

Raymond Bourgoing  
Hervé Todem

## Intercropping COCOA with OIL PALM or COCONUT

INNOVATIVE SYSTEMS  
IN COCOA CULTIVATION

*Setting up a new plot on fallows  
or savannah areas*

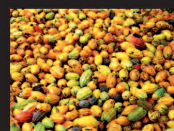
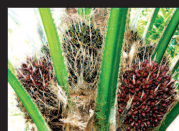



# Intercropping COCOA with OIL PALM or COCONUT

Innovative systems in cocoa cultivation  
*Setting up a new plot on fallows or savannah areas*

Raymond Bourgoing  
Hervé Todem<sup>2</sup>

<sup>(1)</sup> *International Cooperation Centre of Agronomic Research for Development (CIRAD)  
Regional head office for central Africa, P.O Box 2572, Yaoundé, (Cameroon).*

<sup>(2)</sup> *Institute of Agricultural Research for Development, (IRAD), Stimulant plants programme.  
P.O Box 2067 or 2123, Yaoundé, (Cameroon).*

© CIRAD, IRAD, 2010



Institute of Agricultural Research for Development (IRAD) P.O Box 2067 or  
2123, Yaoundé, Cameroon

Tél : +237 - 22 22 33 62, Fax : +237 22 22 59 24

Email : iradpnrva@yahoo.com

Web site: [www.irad-cameroon.org](http://www.irad-cameroon.org)



International Cooperation centre of Agronomic research for Development  
(CIRAD).

Regional office for central Africa, P.O Box 2572, Yaoundé (Cameroon)

P.O Box 2572, Yaoundé, Cameroon

Tél : +237 22 21 25 41, Fax : +237 22 20 29 69

Email : [cirad-cm@cirad.fr](mailto:cirad-cm@cirad.fr)

Web site: [www.cirad.fr](http://www.cirad.fr)

English version

Samuel Nnah and Raphaël Ambassa

Typesetting

Guy Tchekoulong, P.O Box 11 871, Yaoundé, Cameroon,

Tél.: 77 71 47 56 / 98 21 36 75

Warning

The points of view expressed here are those of the authors and in noway involve the institutions to which they are attached. The authors suggest recommendations which are the fruit of their own observations. They do not cover the entire local, geographical, biological, climatic or pedological conditions and may require complementary adaptations.

# Table of content

---

- 9 Introduction
- 11 Site selection
- 13 Land preparation
- 20 Preparation of plant materials and rootstocks
- 28 Establishment of temporary shading
  - Preparation of planting materials
  - Digging of holes
  - Transplanting
- 30 Sowing of food crops
  - Sowing periods
  - Recommended food crops
  - Land preparation
  - Sowing area
- 35 Transplanting
  - Establishment of seedlings
  - Fertilizing
- 39 First year farm maintenance
  - Weed control of food crops
  - Mulching
  - Replacements
  - Control of *Imperata*
- 43 Establishment and management of cover crop (*Brachiaria brisantha*)
  - Production of suckers and plantlets
  - Dissemination of *Brachiaria*
- 51 Mineral fertilization
  - Types of fertilizers and standard rates of application
  - Method of fertilizers application

## Some symptoms of mineral deficiencies in cocoa

65 Pests and diseases control

85 Management of trees

Cocoa

Oil palm

92 Harvesting of cocoa

Harvesting equipments

Ripeness criteria

Cocoa pod breaking

Transportation of cocoa beans

95 Processing cocoa beans

Fermentation

Open air drying

100 Oil palm Harvesting

Maturity criteria of palm bunches

Harvesting tools

Assembling harvested fruits

105 Production forecasts

Production forecast for a one ha of  
cocoa-oil palm plot (kg)

Production forecast for a one ha of cocoa-coconut  
plot (kg)

107 Estimated operating account

Plantations derived from cocoa and  
palm tree selected plant material

Plantations derived from hybrid cocoa seeds  
and from mass selected coconut plant material

109 Planting layout

Cocoa-oil palm interplanting

Cocoa-coconut trees interplanting

# *Acknowledgements*

The authors extend their special thanks to; Robert Ayaga, Emile Ohono and Ernest Keneke, community organisers and leaders of farmers' organizations who, through their hard work and sacrifices, have set a network of pilot demonstration fields whose results have enabled the development of this guide.

The authors also thank Abolo Dieudonné, researcher at IRAD and a passionate collaborator of this initiative for his decisive role in the establishment and facilitation of the Participatory Research Network.

Our thanks go also to Rene Mekondane, an experienced technician and efficient collaborator who was strongly involved in training and monitoring of cocoa farmers.

Finally, the principal author deeply thanks his colleagues from CIRAD, i.e.: Olivier Sounigo, cocoa breeder, for the logistics and technical support he provided to the project, and Regis Babin, entomologist, for his advice and photos that have enriched this guide.







## Introduction

Since the end of the 80s, cocoa growers in Cameroon have experienced a low level of income due, among others, to the low productivity of cocoa trees. The average yield is estimated at about 300 kg of dried cocoa beans per hectare. The low level of adoption of the results and recommendations of cocoa research as well as the fact that the technologies developed do not respond to the real needs of the producers are among the causes of the low yields observed in cocoa farms. In addition, the insufficiency or complete absence of technical management, and extension staff in the field makes the situation worse. In a context marked since 2000 by rising cocoa prices in the international market, farmers are determined to boost cocoa production. A particular emphasis is placed on the diversification of income sources through the development of mixed cropping systems, but yields of cocoa and interplanted crops remain low. The objective of this technical guide is to contribute in providing support to farmers in the process of building innovations in cocoa farming.

This guide is based on the results of pilot trials conducted since 2006 in 168 plots in the villages of Bakoa and Kedia in the Mbam-et - Inoubou division, and Ezezang in the Lékié and Ngat in the Mefou-et-Afamba divisions respectively in the Centre Region

of Cameroon.

A large network, with the development of new technologies, has been established:

- 143 farmers supported by 16 cocoa producers' groups took part in the activities of participatory research;
- the technologies tested include: (i) planting design for associating cacao trees with other perennials such as oil palm or coconut trees and pluriannual crops such as plantains, (ii) promotion of performing plant materials, (iii) use of a cover crops in cacao-based cropping system, (iv) the technique of producing plantain seedlings through a vegetative multiplication by fragmentations (called "PIF" in french), and (v) methods of managing cocoa plantations. This technical guide, **Intercropping COCOA with OIL PALM or COCONUT**, is also meant to help project managers and agricultural and development technicians in decision making.



## Site selection

A good choice of the land to establish the project would require a basic soil analysis of the site.

- **Plot size and Location:** The site must be easily accessible and as close to the farmer's house as possible (Picture p.22).

The recommended standard size of the plot, taken into consideration the investment capacity and the potential work load of an average farmer, should have a surface area of 0.50 hectare, i.e.: 62 m x 84 m. However, the dimensions of the cleared plot must be extended to 75 m x 95 m including the borders.

Remark:

In case the farmer wishes to extend his project, he is advised to put in place a plot of 0.50 hectare every 2 years so as to consolidate the establishment of the preceding plot.

- **Topography** : Avoid sloping lands with slope gradient above 10% in order to ease traffic within the farm during farm maintenance and harvest. Avoid the hilltops which could be easily eroded and lowlands which may be too clayey or too sandy.

- **The soil** : Cocoa can grow on very diverse soil types. However in equivalent climatic conditions, deep and rich soils will be much more favourable to the development and production of the cocoa tree.

- Sandy clay soils rich in nutrients are preferred. The minimum acceptable depth to allow the appropriate development of the tap

root is 1.5 meters. It should even be deeper when rainfall is inadequate or poorly distributed.

- Soil structure should be well developed and homogeneous to allow good penetration of the roots.

- Soil texture for a cocoa farm should have properties that permit good water retention, and adequate aeration and drainage.

- **A high organic matter in the topsoil is essential for a good development of the cocoa trees, thereby assuring good yields.**

The organic matter is generally concentrated in the topsoil that should be preserved from any degradation during site preparation for planting.

**- Farming history:** If the selected site for the cocoa farm is to be located on a fallow land, avoid soils that have undergone several cycles of root and tuber crops like cassava, cocoyams and sweet potatoes that must have chemically depleted the soil. A careful observation of the sites will permit to avoid soils conducive to the development of root rots, by examining rotting tree trunks and logs.



## Land preparation

- **Date** : It is very important to start the operations for land preparation at the beginning of the long dry season for sites requiring the felling of trees. For herbaceous fallows , the operations would begin in the month of February, i.e.: not later than one month before the start of the rainy season. In both cases transplanting cocoa seedlings should be scheduled to take place in the middle of the month of May. The farmer bear in mind that site preparation for the establishment of a mix-cropping farm (e.g. cocoa-fruit trees) takes time; consequently a good preparation will benefit the future development of the cocoa and fruit trees.

- **Chronogramme of activities** for the establishment of a cocoa plot or a network of cocoa plots within a farmers' group:

Month											
Jan.	Feb.	Mar.	Apr.	May	Jun.	Jul.	Aug.	Sept.	Oct.	Nov.	Dec.
Identification " various farmers " and formation of " farmers' group leaders "											
											Sites selection
Preparing sites for planting			Setting up oil palm or coconut nurseries					Setting up cocoa nursery			
		Pegging /holing			Establishment of the multi-species plot (cocoa, oil palm or coconut, plantain)						
Method "PIF" for banana plantain										Method "PIF" for banana plantain	
		Sowing 1 <sup>st</sup> cycle foodcrops					Sowing 2 <sup>nd</sup> cycle foodcrops				
Follow-up of the design / backing farmers / training / network animation											

- **Clearing:** In savannah, clearing of the land for cocoa usually follows the calendar of site preparation for food crops, usually in late February or early March. After slashing it out, the vegetation is burnt to ease tillage operations.
  
- **Felling of trees:** A few palm trees or spontaneous forest trees that have been conserved in the savannah or fallow should be cut down. The wood rounds from sawn trunks and branches are then gathered in heaps or windrows with the slashed grasses and trees biomass.
  
- **Removal of stumps:** It is important to eliminate as many stumps and roots of trees as possible, otherwise, they may become potential hosts for root-rot pathogens.
  
- **Burning:** Burning is more efficient during the dry season and biomass from land clearing is burnt 4 to 6 weeks after felling of trees (Figure p.22). The woody materials that do not get burnt during the first burning are gathered for further burning.
  
- **Preparing pegs:** Palm fronds from the palm trees felled during land preparation are used to make pegs of 1.20 m that will be used during the pegging of the plot. Before burning, all other woodsticks, 2 to 3 cm in diameter, can also be used to make pegs. 800 pegs will be needed for pegging the plot.

- **Planting layout** : Comply with the diagram below for the establishment of a cocoa-fruit trees plot of 0.50 hectare (\*):

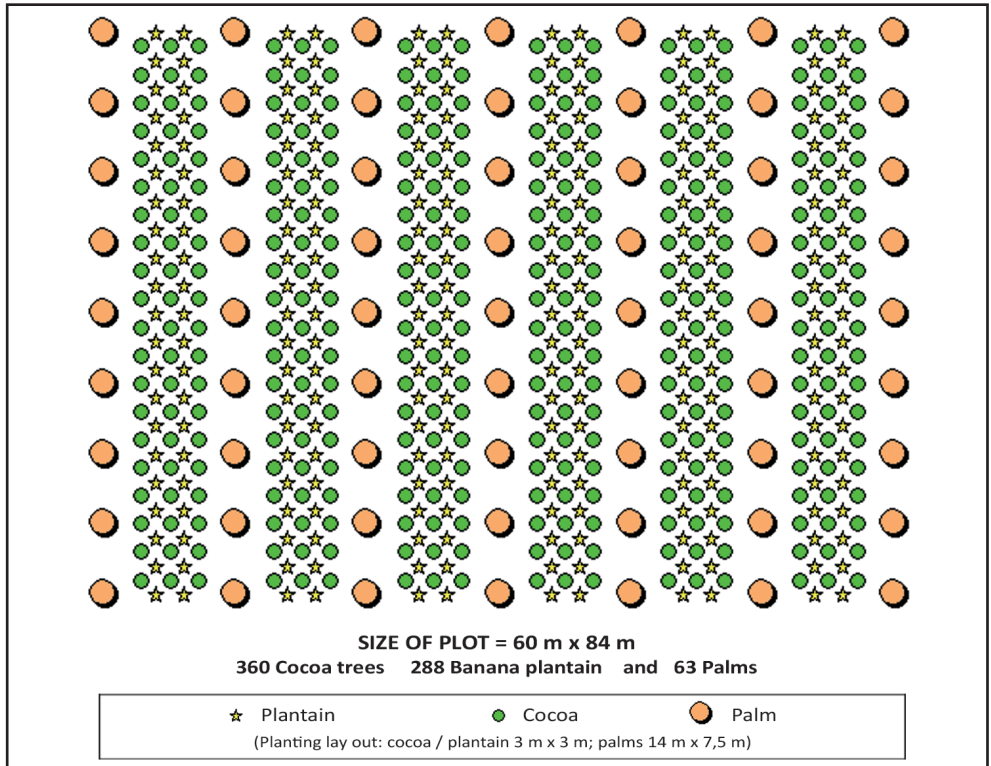

(\*) Surface area corresponding to the investment and work load capacity of a farmer during a cropping season. Cocoa-coconut planting layout is also available (see Chapter XVII).

- **Pegging** : This operation must be performed with a lot of care and precision respecting the spacing (Picture p. 22).

Materials needed :

- 80 m nylon rope
- 20 m tape

## Method :

Follow the 4 steps outlined below:

1- First establish a reference line by placing the nylon rope over the entire length of the plot, at least 84 m. Place the tape on the rope and mark with a peg every 14 m (these pegs materialize the start of lines for palm trees; for coconuts, these pegs will be placed at every 12 m), stop at the 7<sup>th</sup> peg. Go back to the first step and make a right angle. This is done in the direction of the width of nylon rope; stretch the nylon rope on at least 65 m and then place the tape mark pegs at every 7.50 m, stop at the 9<sup>th</sup> peg.

2- Return to the second peg of the reference line, start line 1 by orienting the nylon rope towards the width and stop opposite and at 14 m from the 9<sup>th</sup> peg, this by placing a reference peg at 14 m from the 3<sup>rd</sup> peg of the reference line and another at 14 m from the 5<sup>th</sup> peg; as such mark every 7.50 m until the 9<sup>th</sup> peg. Repeat the operation until the 7<sup>th</sup> peg on the reference line; this gives a set of 6 blocks demarcated with 7 lines with 9 pegs each giving a total of 63 pegs that represent the location of palm trees.

3- To materialize the location of cocoa and banana, stretch the tape between the two first pegs of the reference line which materialize the lines for palm trees of which the interval is 14 m (12 m for coconut); place the pegs at 4 m from the 1<sup>st</sup> (palm) peg then at 7 m and finally at 10 m; follow the same procedure for the installation of pegs between the 5<sup>th</sup> palms of the first block, these pegs will be used only as reference points; place the tape



between the pegs that are at 4 m, mark the 3m spots, do the same for pegs that are on 7 m and finally with those at 10 m (the reference pegs are either eliminated or adjusted). Replace the reference pegs between the 9<sup>th</sup> peg for palm and repeat the same procedure. For banana plantains, place a template (a 4 m long palm frond marked in the middle) at the diagonal of the square formed by four pegs established for cocoa, the middle of the template is the location to plant plantain. Proceed in the same way for the five other blocks.

See diagram

### - Phase to establish palm tree rows

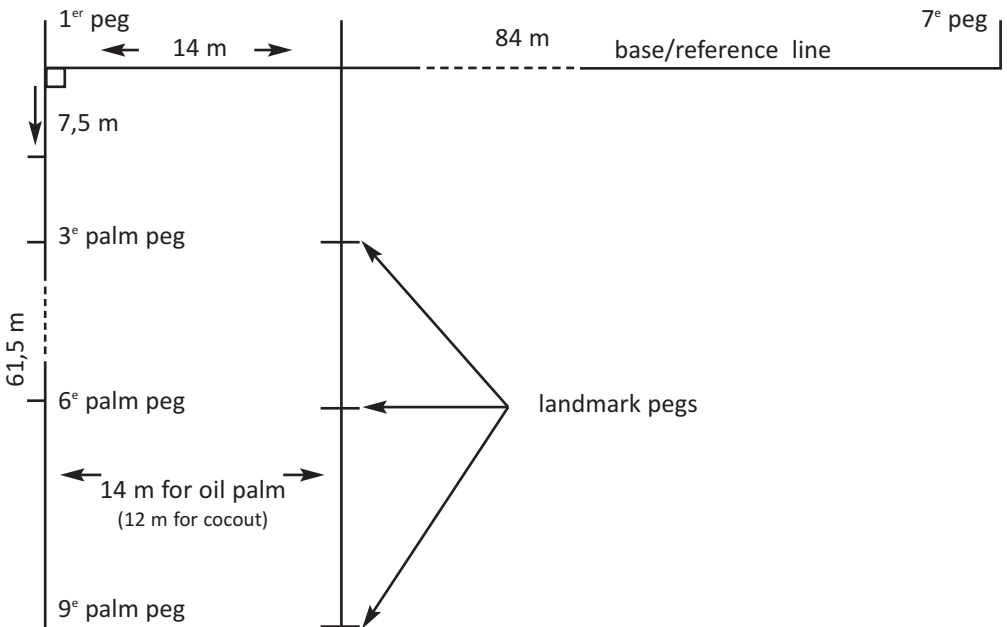

## - Phase of filling the blocks between the palm rows

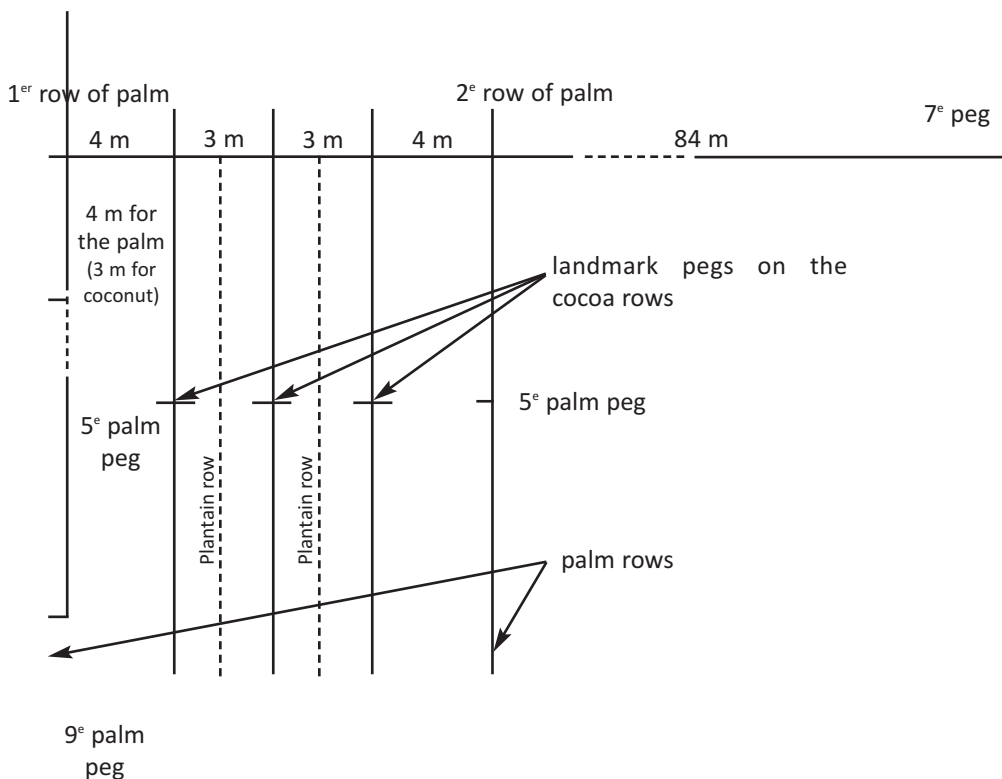

- **Digging planting holes** : digging follows pegging, and should start just after the first rains at the beginning of the rainy season. The planting holes are dug where the pegs are placed. Respecting the norms on the size of the planting holes will guarantee an enabling environment for the rapid development of the root system of the plant and a proper take off after transplanting.

The dimensions of the hole should be respected scrupulously:

- Cocoa, 40 × 40 × 40 cm;
- Palm or coconut, 50 × 50 × 50 cm;
- Plantain, 30 × 30 × 30 cm.

It is imperative to use a gauge, calibrated to the dimensions required to measure each hole; a stick or just the handle of a hoe or digger well calibrated and can be used guage.

Equipments used: Digger, hoe, calibrated gauge.

Method: During digging and in the case of even slight slopes, the black topsoil should be placed towards the top of the slope, whereas the brown soil should be placed at the edge of the hole, down the slope, so as to prepare the construction of an individual plant terrace during planting.

**- Planting density with respect to type of crop association and by species:**

Species	Number of trees / hectare / type of association	
	cocoa-oil palm Intercropping	cocoa-coconut Intercropping
Cocoa tree	696	813
Plantain	557	650
Oil palm	122	-
Coconut tree	-	142

In the fruit-tree-hedge design chosen for intercropping cocoa and oil palm trees or cocoa and coconut trees, the palm and coconut trees should play the role of windbreak and shading for cocoa. The adoption of the fruit-tree-hedge design, by reducing competition among trees, does not permit the development of the oil palm or coconut trees to happen to the detriment of cocoa trees.



## Preparation of planting materials and rootstocks

Nurseries are established during the year preceding the putting in place of the cocoa farm, that is, in the beginning of the rainy season (March-April) for the nursery of palm trees ( Pictures p. 23,24,25) or coconut trees (Pictures p.26, 27) and in September-October (harvest period for pods) for the cocoa nursery. The standards and norms for the creation of nurseries should be respected in order to obtain healthy and vigorous plants:

- **Use selected hybrid seeds:** For cocoa and palm, the seeds should be ordered from centres specialized in the production of improved plant materials whose origin is guaranteed. In Cameroon, more than 15 varieties of selected hybrids are now being produced and disseminated in controlled and certified cocoa seed production fields (Pictures p.21).

List of major cocoa crossing/hybrids disseminated in Cameroon :

- IMC 67 x SNK 64      - T 79/501 x SNK 109      - T 79/501 x SNK 13
- IMC 67 x SNK 109      - SNK 16 x SCA 12      - UPA 134 x ICS 40
- T 79/501 x SNK 13      - UPA 143 x SNK 64      - T 79/501 x SNK 16

Improved seeds of oil palm that are commercialized are obtained by hybridization. Consequently, it is strictly recommended to farmers not to use the products of their own palm trees to establish new plantations (Pictures p.23, 24).

Coconut seeds will be obtained from natural coconut hybrids "Tall

coconut varieties", easily found around some villages. They are high yielding varieties, producing more than 100 nuts/tree/year, and they look more vigorous than the coconut "Local tall", with a larger number of fronds. The number of bunches is also higher while the nuts are bigger. To reproduce most of the characters of the selected mother-tree, it is recommended to harvest mature seed-nuts from isolated trees (no other coconut trees located within 400-500 meters around).

- **The location of the nursery:** It should always be near a water point which does not dry up in dry season.

- **The nursery is made with plastic bags** (black polyethylene, 15-20/100000 mm thick).

Size of the polyethylene bags :

- Cocoa : 20 × 30 cm ;
- Palm : 30 x 40 cm ;
- Coconut : 40 × 40 cm.

- **Filling the bags** Use the top black soil rich in organic matter (collected from the forest). The bags are filled up to the upper edge, after planting and watering several times the soil will sink by 2 to 3 cm.

- **Placing the bags:** The bags are placed in double line rows and slightly buried to ensure proper grip. Keep a distance of 60 cm between each double row to ease walking in the nursery during maintenance and watering of the plants (Pictures p.22, 24).

- **Daily watering in sufficient quantity** during the dry season is crucial in order to obtain healthy and vigorous plants.



Selection of a planting site by a group of farmers.

*Pictures R.Bourgoing*



Land preparation works for the establishment of a cocoa-fruit trees plot.



Installation of the planting layout, pegging works.



Installation of a cocoa trees nursery with the introduction of hybrid varieties: beans are separated from mucilage before sowing, scrub seeds using sand and water (arrow); a temporary shading of the polyethylene bags to protect seeds germination after sowing.



Cocoa seeds germination in a nursery protected by a shade made up of palm fronds.



A nursery of 8-month-old cocoa seedlings. Removing seedlings for transplanting.



Pre-germinated seeds of selected oil palm hybrid (*Tenera*) from IRAD seed farm.

Use of a plantain propagator, with red wood sawdust substrate, as "pre-nursery" for sowing the pre-germinated seeds.

Sowing depth: 1-2 cm; daily watering; make sure that the substrate is well moistened in depth. Maintain the propagator under a well closed translucent white plastic tarpaulin.



3-month-old seedlings ready for transplanting in the nursery.

*Pictures R.Bourgoing*



Trimming and puddling of roots of young seedlings before transplanting in polyethylene bags. The roots are trimmed at 5-7 cm long before being soaked in a muddy mixture of earth and cow dung.

Mix well to get a homogeneous medium.

Transplanting of oil palm seedlings. Water thoroughly immediately after transplanting to ensure a good compaction of the soil around the roots.



Cocoa-oil palm nursery.

Watering every two days during the dry season, preferably in the evening and in sufficient quantity to wet the entire soil clump on each pass.

*Pictures R.Bourgoing*





Well-managed 5-month-old oil palm nursery.

Recommendations of fertilization in the nursery; rate (a beer cap full to a cone shape) per seedling/month, applicable also to coconut trees.

- 2nd month: 1 beer cap of triple **superphosphate** (Triphos) fertilizer;
- 3 to 5 months: 2 beer caps of **20-10-10** + 1 beer cap of **coarse salt**;
- 6 to 9 months: 2 beer caps of **20-10-10** + 2 beer caps of **urea** + 1 beer cap of **coarse salt**;
- 10 to 12 months: 3 beer caps of **20-10-10** + 2 beer caps of **urea** + 1 beer cap of **coarse salt**.



A young oil palm tree intercropped with maize.

*Pictures  
R. Bourgoing*

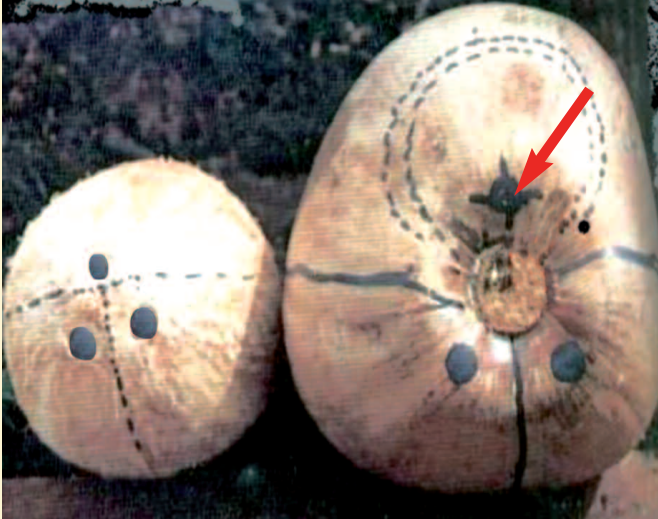

Before notching the coconuts for sowing in seedbeds, identify the germination point. Sprouting of the germ from the largest bulge of the nut (see arrow).

Notch a thin portion of the husk using a well sharpened cutlass; diameter: 5 cm, thickness: 1 cm.



Sowing of notched nuts in seedbeds; width of seedbeds: 1.50 m. Place the nuts slightly oblique, the notched part being placed upwards.



## Transplanting of germinated seednuts:

**A :** Uproot the germinated seednuts whose shoot is at least 5 cm long;

**B :** Remove the soil from the bag so as to well position the nut in the centre of the bag with the shoot in the vertical position;

**C :** Return the soil previously removed from the bag up to a level where it slightly covers the nut;

**D :** Nursery of coconut seedlings 3 months after transplanting of germinated nuts.

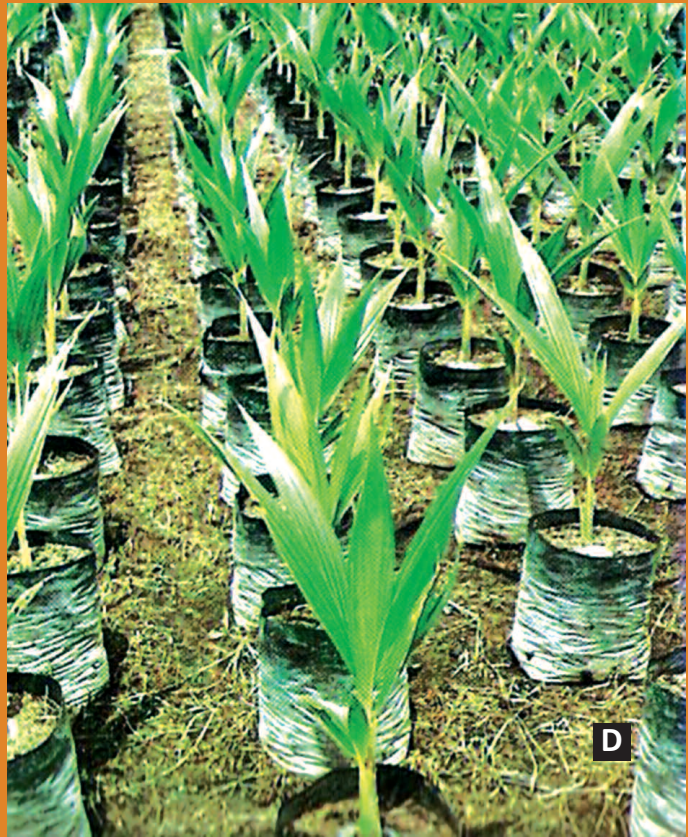

*Pictures R.Bourgoing*



## Establishment of temporary shade

The temporary shade is established by planting banana plantains whose development and density naturally reduce over time and completely disappear from the layout by the 4th year. The planting materials for banana plantain could be obtained locally or from a centre specialized in the production of improved plantain varieties, from where one can have access to high performing plant materials and opt for varieties of average size, better resistant to the strong winds of the start of the rainy season.

### Preparation of planting materials

- **Collection of young suckers** of plantain (“bayonet” stage) from local orchards. Collect best varieties, whose bunches are best valued on the market (Essong, Elat....varieties).

- **Production of plants from Fragmentation** (“PIF”). This method of rapid multiplication of plantain permits to obtain from young bulbs/suckers very healthy plants that are free from parasites (nematodes, weevils). The prepared bulbs are placed in a propagator to foster the sprouting of young shoots/seedlings that will be removed from the bulbs every 8 to 10 days and transplanted into plastic bags of 17 × 24 cm dimensions.

The plants are raised in plastic bags under shade for 3 months (Picture p.31).

## Digging holes

Respecting the digging norms permits a good start of growth of the plants and contributes in establishing a strong root system and hence giving the plantain a good grip on the soil and greater resistance to wind.

The dimensions of the planting hole are 30 × 30 × 30 cm.

## Planting

The establishment of plantain seedlings is carried out in the very beginning of the long rainy season, in April (Pictures p.32).

Filling back the planting holes is done using the black topsoil, a hollow is kept around the plant to collect the first rains and so facilitate the good growth of the plant.



## Sowing food crops

Sowing food crops add value to the cleared field, complete the cleaning of the plot (eradicate *Imperata cylindrica*, *Eupatorium*, ferns etc ...) and this favours the development of young cocoa trees and palms or coconut trees. Food crops are cultivated on the land during the first two years (Pictures p.32 ,43, 44).

### Sowing periods

Two sowing cycles of food crops could be carried out per year corresponding to the long and short rainy seasons:

- April to May and
- August to September

The choice of food crops to be sown could be guided by the eating habits in the area or by the market, also the nature and level of soil fertility should also be taken into consideration. It is recommended to use a leguminous crop (groundnut, soya) in April-May; the farmer could intercrop it with maize at low density.

During the next cropping season, August-September, which correspond to the short rainy season, the farmer could grow maize on the land. The maize will ensure a temporary shade for the young cocoa plant during the dry season in December-January. Other plants such as pepper, tomato and egusi could be planted during the second cycle in year 1.



Preparation of explants (plantain bulbs/suckers) for the production of “Pifs” or plants derived from “fragmentation”. Fungicide and nematocide spray mixture to soak the suckers (arrow) before sowing in the propagator.

*Pictures R.Bourgoing*

Management of a propagator for the rapid multiplication of plantain; collection of young seedlings every 10 days from the explants taken out of the substrate (sawdust)



Removal of an explant from the propagator to extract plantlets for transplanting, and 4-month-old plantain nursery. Removal of seedlings for their transplanting in the field.

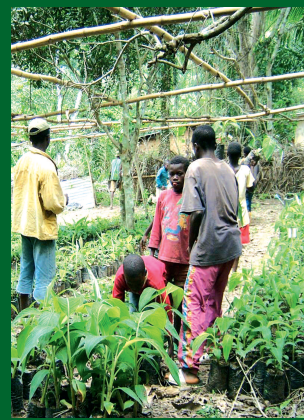



Planting of plantain under maize shade.

*Pictures R.Bourgoing*

Food crops (maize or groundnut) planting in year 0 and just prior to the establishment of cocoa and other fruit species.



Development of temporary shading on plantain with groundnut being grown in year 0.



		Recommended Food crops			
		Year 0		Year 1	
		April-May	Aug-Sept.	April-May	Aug-Sept
Area	Type of association				
Forest	Cocoa - palm	Groundnuts-soya+maize	Maize, rice + pepper	Groundnuts-soya+maize	Maize, rice
	Cocoa - coconut	Groundnuts-soya+maize	Maize, rice + pepper	Groundnuts-soya+maize	Maize, rice
Savanna	Cocoa - palm	Groundnuts-soya+maize	Maize + pepper or egusi	Maize	Egusi +Maize
	Cocoa - coconut	Groundnuts-soya+maize	Maize + pepper or egusi	Maize	Egusi +Maize

## Land preparation

- **Savannahs with *Imperata*** could be slashed and burned. This operation is followed by tilling of the soil. The complete eradication of *Imperata* could be obtained the following cropping season by applying a systemic herbicide such as glyphosate (Glyphader, Round Up ...) on the newly developed *Imperata* at the rate of 4 litres of the commercial product per treated hectare.
- **On fallows with *Chromolaena***, the same procedure as with *Imperata* could be followed; it has the advantage of reducing the need for herbicide with preliminary mechanical control. A good tillage has the advantage of ensuring a clean soil, good food crop production and increases resistance of the young cocoa to drought during the dry season that follows the establishment of plants; the mortality rate of cocoa could be reduced from 30-40% (on non-tilled soil) to less than 5%.

## Sowing area

- **Year 0** : 100% plot area with groundnuts or soy during the 1<sup>st</sup> cycle in April- May. In 2<sup>nd</sup> cycle in August - September , for maize and other recommended food crops, avoid planting too close to the perennial crops. Allow loose a 1 metre diameter circular area around the plants.
- **Year 1** : For the first cycle, 100% of the plot area could still be used to grow groundnuts + maize in the cocoa - oil palm or cocoa - coconut trees association.
- **Year 2** : In these two association models, only planting strips of oil palms, with a width of 8 m or coconut trees (width 6 m) are often cultivated with maize, whereas the cover crop has already been installed on the planting strips of cocoa trees.



## Planting

### Establishment of seedlings

It is essential that **planting is done about one month after the onset of the rainy season**, early in June and when the rains become frequent. In case the land is on a slope, individual terraces will be made during planting, only the black topsoil placed close by the hole (by the time of holing) and upward on the slope will be used to refill the hole. The brown or red subsoil placed downwards on the slope during digging the holes will serve to retain rainwater. A circular hollow area of 1 meter diameter and 5 to 10 cm deep will also be made around each plant to allow storage of water and ensure a good start of growth of the plants.

#### Precautions to take during planting:

- **Select the seedlings** before planting (a 6 month-old cocoa seedling should have a minimum height of 60 to 70 cm with a stem diameter at its base of 0.8 to 1 cm or equivalent to the size of a pen), do not plant stunted seedlings that will not survive the next dry season;

For an oil palm tree aged 10-12 months, the circumference at the collar should be between 20 to 25 cm for a height of 0.80 m to 1 m, with 7 to 8 green palm fronds.

- **Water the seedlings thoroughly** the day before removing them from the nursery;

- **Carry the seedlings to the farm the same day of planting**, planting should take place early in the morning or late in the afternoon;
- During planting, **remove the plastic bag** using a knife or a very sharp machete, without breaking the clod of earth (Pictures p.38);
- **Pile enough soil** while refilling the hole;
- **Create a hollow** and on slope an individual terrace around each plant.

## Manuring

A basic fertilizer application is required for oil palm or coconut.

Dose : 300 g/ plant of composed fertilizer 20-10-10 (NPK) to be mixed homogenously with the soil when refilling the hole during planting (Pictures p.38).

Chicken droppings or the faeces of small ruminants can also be used; these organic fertilizers are preferably spread on the surface of the hollow round the plant after planting.



Making planting holes: this phase of land preparation requires a group work.

The transportation of cocoa seedlings to the plot is accomplished with very good care by avoiding damaging the bags and breaking soil clods.



Cocoa plot grown to maize. Maize stalks, after drying, will serve as temporary shading to young cocoa trees during the dry season.

*Pictures R.Bourgoing*



**A**

## Transplanting of oil palm or coconut trees:

**A** : Mix 300 g of 20-10-10 fertilizer with the soil meant to refill in the holes.

**B** : Adjust the depth of the hole by adding black topsoil if necessary; after transplanting, the plant collar should be 6-7 cm below the ground level.

**C** : Open the side and bottom of the polyethylene bag and turn it out halfway.

**D** : Position the plant in the hole.

**E** : Fill the hole with black topsoil half-way, compact and raise the bag.

**F** : Add soil and remove the bag.

**G** : Recover the clump with soil up to the collar level, compact firmly.



**B**

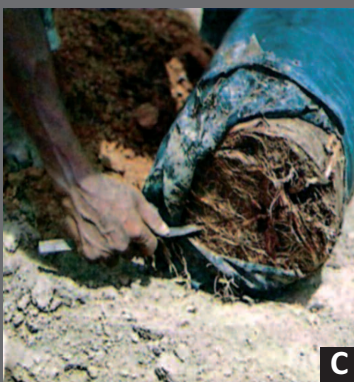

**C**



**D**



**E**



**F**

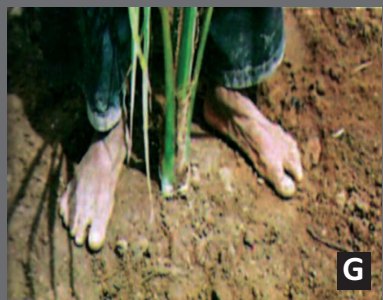

**G**

*Pictures R.Bourgoing*



# ETS NJ Provenderie Moderne Plus

**DIVERSIFIEZ VOS REVENUS AVEC L'ELEVAGE DU POULET DE CHAIR,  
DU PORC ET DES PETITS RUMINANTS**

## I- Nos missions

- Professionnaliser les activités de l'élevage au Cameroun
- Valoriser le métier d'éleveur
- Formation gratuite et continue des éleveurs



## I- Nos forces

- Un personnel accueillant
- Une équipe de techniciens qualifiés et disponible pour le suivi de vos élevages
- Des partenariats solides avec les grandes structures d'élevage pour répondre à vos exigences
- Dynamisme de la recherche dans le domaine des technologies animales



## I- Nos produits

- Des poussins de races performantes
- Des porcelets et géniteurs de races améliorés
- Des produits (aliments complets, matières premières) de qualité pour une nutrition réussie dans vos élevages



**BP: 2763 Yaoundé Tél.: (237) 22 06 87 91 / 75 51 00 01 / 96 27 00 62**

**Situé au côté de la TOTAL Nkolbisson**



# ETS NJ

## Provenderie Moderne Plus

### QUELQUES INSTALLATIONS D'ELEVAGE EN MILIEU PAYSAN

#### Élevage aviaire :



Poulet de chair  
1<sup>e</sup> âge

Poulet de chair  
2<sup>e</sup> âge

Poulet de chair  
3<sup>e</sup> âge

#### Élevage porcin :



Bâtiment en dur

Porcherie moderne  
en construction

Animal reproducteur





## First year farm maintenance

Proper maintenance of the cocoa farm is essential when establishing the crops, this is to ensure a healthy growth, an effective pest and disease control and avoid competition for nutrients and water with weeds. Thorough farm maintenance permits the different plants to grow fast as well as express their full production potential.

### Weeding the food crops

Regular weeding of food crops (groundnut, chilli, soya, maize ... etc.) during the first two years, in addition to improving the income of the farmer, also helps to keep the cocoa plot clean and permit the proper establishment of the cover crop (*Brachiaria*) during the second year (Pictures p.43, 44).

### Mulching

Mulching the crops is necessary in the first two years to ensure good water retention by reducing evaporation. In addition, it reduces erosion especially on slope and prevents rapid re-growth of weeds. The decomposition of the mulch and crop residues also constitutes a supply of organic matter which is beneficial to young tree crops. Crop residues from groundnut, soya and maize stalks after harvest, are disposed over a circle of 2 meters diameter around the plants (Pictures p.43).

## Replacements

Replacement of trees that died during the dry season after planting is done in the beginning of the next rainy season, preferably in May. This operation involves the establishment of a new nursery in September- October of the year planting is carried out.

In a well managed farm with good cropping practices and a soil conducive to cocoa growing, the mortality rate in the first year does not exceed 5-10%. Dead trees during the dry season following planting could still be replaced in the second year.

## Control of *Imperata*

The cultivation of food crops in the first two years will almost entirely eliminate the *Imperata cylindrical* weed.

In the case of re-growth with a high density, it is advisable to carry out chemical treatment with glyphosate (Glyphader, Roundup ...) at a dosage of 4 litres of the commercial product per hectare or 130 ml / 15 litre sprayer (use the measuring cup usually supplied with the purchase of a sprayer). Three weeks to a month after the first treatment, a corrective treatment will be necessary to control untreated spots during the first treatment.

As early as the third year, with a total coverage of the soil by *Brachiaria*, *Imperata* is totally controlled.



A 15-month-old oil palm tree, after establishment in a maize field. Individual hollow and terrace were made to retain water and control erosion

Growing groundnut in year 0 i.e. the year of plot establishment is beneficial to the striking of the cocoa seedlings with improved earliness of plant crown.

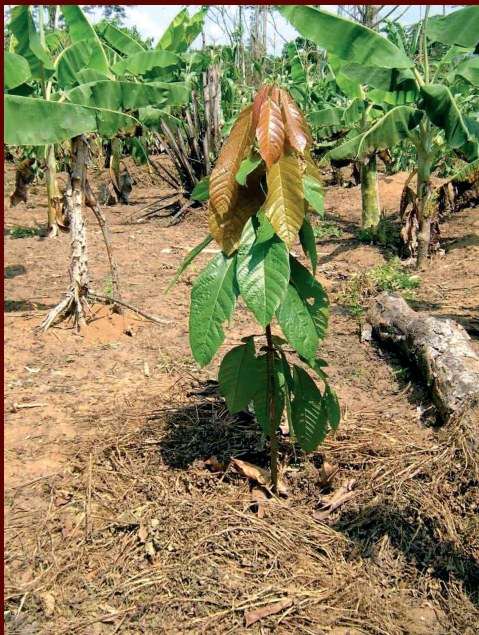

Crop residues, here groundnut haulms, are used for mulching cocoa rings.



Maize grown in the intercropping with palm tree, or groundnut with coconut tree in year 1 (year following planting). In addition to the income generated by food crops, this system permits a good cleaning of the soil useful to the development of the young plants.

*Pictures R.Bourgoing*





## Establishment and management of cover crop (*Brachiaria brizantha*)

The establishment of the cover crop *Brachiaria brizantha* is intended to reduce farm maintenance cost, labour and to improve the structure, fertility and biological content of soil by providing high biomass.

The installation of the plant cover must be made at the beginning of the rainy season by the method of cutting or throughout the rainy season with the use of rooted plantlets.

### Production of suckers and plantules

There are already enough new plots in the Centre Region of Cameroon (Bokito, Awaé, Obala) with the *Brachiaria* cover crop well established which can be used for its propagation and dissemination.

Propagation could be carried out by using cuttings, rooted suckers obtained from the stems or with the removal of plantules that grow around the old stumps of *Brachiaria* (Pictures p.49).

### Dissemination of *Brachiaria*

- **By cuttings** : Remove the already hardened stems on an old stump of *Brachiaria*; a cutting is constituted from the 20 to 30 cm stem removed at from the base. Cuttings should be planted in the field on the same day of collection.

- **Use of suckers** : As the *Brachiria* ages the stems closest to the ground produce suckers with roots. Suckers are easily detachable from the stems, they can be planted within 2-3 days provided they are kept after moistening in a closed plastic bag.

- **Removal of plantules** : These comprise of young *Brachiarria* plants with a well developed root system and being derived from seeds that germinated around of the old plant. The delay before planting could take up to a week if the plantules are kept in a moist environment.

- **How to establish *Brachiarria*** :

Period : latest in the second year and at the same time as the sowing of a food crop. Planting thus takes place in May, therefore at the very beginning of the rainy season.

Planting layout: *Brachiarria* is only planted on the plantain row. One to two suckers or plantules are planted between plantains. If the technique of cuttings is chosen, two to three cuttings should be put in each planting hole.

Planting: open a hole 5 to 7 cm depth with the tip of the machete, place the plantules or suckers, remove the machete and restore the soil with your foot, compress the soil with the heel so as to leave a small hollow that will retain water thus facilitating a healthy growth of the seedlings.

In the case of cuttings, place 2 or 3 half lying cuttings in a hole and bury at least at 10 cm.

Conduct: six months after harvesting food crops, *Brachiaria* will cover approximately 80% of the area of the plot.

In case of the presence of *Imperata cylindrica*, a selective weeding with herbicide glyphosate will be needed outside the planting line of *Brachiaria*.

By the third year and after getting full coverage of the plot, the control of *Brachiaria* begins only on the rows of cocoa and on a 1.50 m wide strip. *Brachiaria* will remain on the rows of plantain in order to reoccupy periodically (after 4-5months) treated strips.

**Calendar of treatment with glyphosate** (Glyphader, Round Up...)

- June (1<sup>st</sup> week) 3 litres / ha of commercial product or 100 ml / 15 litres of water.
- November (1<sup>st</sup> week) 4 litres / ha or 130 ml / 15 litres.

On very fertile soils, intermediate treatment could be done in September to reduce the development of *Brachiaria*.

This method permits the accumulation of more and more mulch on the cocoa rows. The constant supply of organic matter after the decomposition of *Brachiaria* (Pictures p.50) and with the respect of other cropping practices will guarantee sustainable production with a steady increase of soil fertility (increase in mineral contents and improvement of biological life).

If necessary, between two treatments, a brief slash with the machete can also be done on the row of cocoa.

As from the 4<sup>th</sup> year the dosage of glyphosate could be reduce (use only 70 to 80 ml commercial product / 15 litres of water). At the 5<sup>th</sup> year, the control of *Brachiaria* on the rows will not be

necessary if the farmer was able retain the original planting density, its development, under the shade of cocoa, reduces every year.

Note however that some farmers choose to use mechanical control of *Brachiaria* by a periodic slashing with a machete at one third of the height and at 3-4 month intervals. This operation is no longer necessary after the fifth to sixth year, with the cover crop having a reduced development under the shade of cocoa.





6-month-old *Brachiaria* stump established through a rooted plantlet.

Rooted plantlet (arrow) of *Brachiaria* growing from an old stem node and that can be used for its multiplication.



28-month-old *Brachiaria* cover requiring control on cocoa rows.



Control of *Brachiaria* by slashing of cocoa rows; look at the importance of biomass and mulch.

*Pictures R.Bourgoing*

Chemical control of *Brachiaria* on the row; width of the strip treated with glyphosate (Glyphader, Roundup, etc.): 2 m; annual number of passes: 2 to 3.



The very dense *Brachiaria* root hairs, with its deep rooting system, contributes to improve the structure and biological environment of the soil; it also plays the role of a "biological pump" by bringing upward to the soil surface nutrients swept in-depth.



## Mineral fertilization

The use of fertilizers in cocoa cultivation is not a very widespread practice. The effect of fertilizer on production is much related to the cropping conditions and light. Less profitable under shade, fertilizers are effective for the unshaded cocoa trees (or medium shaded) and only if all other cropping conditions are properly controlled.

### Types of fertilizers and recommended standard rates

#### - Association cocoa tree - oil palm

Associated plants	Fertilizer (g/tree)					
	6-15-28-6-3	20-10-10	Urea	Nacl (salt)	Borax	Fertibore
<b>Cocoa tree</b>						
Year 1	100	-	-	-	-	20
Year 2	150	-	-	-	-	40
Year 3	200	-	-	-	-	80
Year 4 and beyond	300	-	-	-	-	-
<b>Oil palm</b> <sup>(3)</sup>						
Planting <sup>(1)</sup>	-	300	-	-	-	-
Year 1	-	500	150	-	10	-
Year 2	-	800	300	-	50	-
Year 3	-	1 000	300	500	100	-
Year 4 and beyond	-	1 700	-	800	-	-
<b>Plantain</b> <sup>(2)</sup>						
Year 1 ; (1 <sup>st</sup> cycle)	-	-	150	-	-	-
Year 2 ; (2 <sup>nd</sup> cycle)	-	-	150	-	-	-

Fertilizer formulation: NPK + CaO + MgO (6-15-28-6-3), NPK (20-10-10).

(1) All holes are refilled with black topsoil mixed with fertilizer.

(2) Application of Urea only on less fertile soils to facilitate the development of plantain and so provide a good shade for cocoa trees.

## - Association cocoa - coconut trees

Associated plants	Fertilizer (g/tree)					
	6-15-28-6-3	20-10-10	Urea	Nacl (salt)	Borax	Fertibore
<b>Cocoa tree</b>						
Year 1	100	-	-	-	-	20
Year 2	150	-	-	-	-	40
Year 3	200	-	-	-	-	80
Year 4 and beyond	300	-	-	-	-	-
<b>Coconut tree<sup>(3)</sup></b>						
Planting <sup>(1)</sup>	-	300	-	150	-	-
Year 1	-	500	100	200	10	-
Year 2	-	800	200	300	50	-
Year 3	-	1 000	300	500	100	-
Year 4 and beyond	-	1 200	-	800	-	-
<b>Plantain<sup>(3)</sup></b>						
Year 1 ; (1 <sup>st</sup> cycle)	-	-	150	-	-	-
Year 2 ; (2 <sup>nd</sup> cycle)	-	-	150	-	-	-

Fertilizer formulation: NPK + CaO + MgO (6-15-28-6-3), NPK (20-10-10).

(1) All holes are refilled with black topsoil mixed with fertilizer.

(2) Application of Urea only on less fertile soils to facilitate the development of plantain and provide a good shade for cocoa trees.

(3) To make it easy for small farmers in the management of fertilizers application on oil palm or coconut, a compound fertilizer (NPK : 20-10-10) is recommended to bring in one application the three major elements which are nitrogen, phosphorus and potassium. However, additional nitrogen will be provided through the application of Urea the first 3 years.

Fertilization is one of the items with the highest costs in the farmer's operating account; therefore it is important to define precisely the economic rates of application, but also to carefully control the quality of applications.

**Louis Dreyfus  
Commodities**

# SPECIAL COCOA FERTILIZER

**ADER**  
**ENGRAIS SPECIAL**  
**CACAOYER**

POIDS NET  
**50KG**



[www.ldcom.com](http://www.ldcom.com)

Douala -Z.I de Bonabéri B.P : 2368 - Cameroun

Tél : +[237] 33 39 91 16 - Fax : +[237] 33 39 16 39

Yaoundé - Tél :+[237] 22 23 59 04 - Fax : +[237] 22 22 34 23

# Louis Dreyfus Commodities

# A COMPLETE RANGE FOR GOOD COCOA



www.fgc-online.net

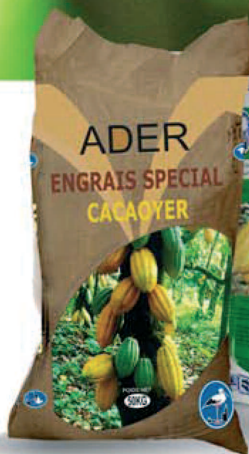

[www.ldcom.com](http://www.ldcom.com)

Douala -Z.I de Bonabéri B.P : 2368 - Cameroun

Tél : +[237] 33 39 91 16 - Fax : +[237] 33 39 16 39

Yaoundé - Tél :+[237] 22 23 59 04 - Fax : +[237] 22 22 34 23

## Method of fertilizer application

- **Application period in May-June**, after the onset of the rainy season.
- **Method of application** : The fertilizers are spread evenly over the entire surface of the circle around the cocoa plant without removing the mulch (Picture p.64); for application of small dosages such as with Boron element (Borax or Fertibore), whose dosis concern only tenths of grammes, the fertilizer can be localized at the axillas of the oil palm or coconut lowest fronds without any risks of burns .
- **Diameter of the circles** :

Years	Diameter of the application circle (cm)		
	Cocoa	Oil palm or coconut	Plantain
1	60	100	60
2	100	200	60
3	150	300	-
4 and beyond	200	400	-

## Some symptoms of cocoa mineral deficiencies

Typical symptoms of various deficiencies, which mainly concern abnormalities of leaves, are well known and could help qualitatively diagnose imbalances in soil minerals. The most frequently observed are:

- **Nitrogen deficiency**: The leaves are small with a discoloration and yellowing of the leaf blade and ribs (Pictures p.57);

- **Boron deficiency:** The young leaves are abnormally elongated, often curled up, clutching at the edge and having yellow spots at the point of curvature. In the most advanced stage, the leaf tip is necrotic (Picture p.57);
- **Phosphorus deficiency:** Leaf tip becomes orange - brown, necrosis expand into yellow lined spots (Picture p.58);
- **Potassium deficiency:** A marginal olive-green discoloration of the leaf is observed, followed by necrosis (Picture p.58);
- **Magnesium deficiency:** Yellow discoloration of both sides of the midrib of the leaf (Picture p.58);
- **Calcium deficiency :** Peripheral drying of leaves with purple-orange and extending to orange-yellow spots with yellow border between the secondary veins (Picture p.58);
- **Iron deficiency :** Chlorosis due to iron deficiency is characterized by discoloration of the last emerged leaves. Presenting in the early stages a pale green, the leaves rapidly turn to yellowish green. Discoloration is interveinal with the ribs still green in colour (Picture p.58);
- **Zinc deficiency :** Very recognizable with the malformation of leaves being very narrow, elongated and often curved with very visible abnormal ribbing (Picture p.58).





The foliage coloration is normal, indicating a good balance of soil nutrients. Note the dark green foliage colour

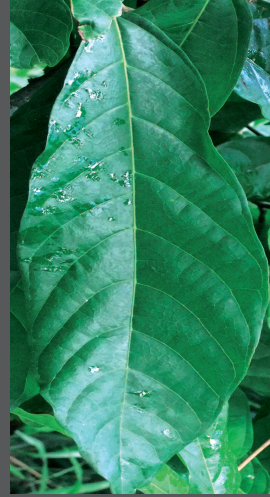

Symptoms of nitrogen deficiency: reduction of leaf size along with discoloration and yellowing of the leaf blade and ribs.



*Pictures R.Bourgoing*



Boron deficiency symptoms: the most advanced stage with necrotic leaves tip.



## Other symptoms of nutrients deficiencies in cocoa



**Phosphorus deficiency**



**Potassium deficiency**



**Magnesium deficiency**



**Calcium deficiency**



**Iron deficiency**



**Zinc deficiency**

## Method of fertilizer application

- **Application period in May-June**, after the onset of the rainy season.
- **Method of application** : The fertilizers are spread evenly over the entire surface of the circle around the cocoa plant without removing the mulch (Picture p.64); for application of small dosages such as with Boron element (Borax or Fertibore), whose dosis concern only tenths of grammes, the fertilizer can be localized at the axillas of the oil palm or coconut lowest fronds without any risks of burns .
- **Diameter of the circles** :

Years	Diameter of the application circle (cm)		
	Cocoa	Oil palm or coconut	Plantain
1	60	100	60
2	100	200	60
3	150	300	-
4 and beyond	200	400	-

## Some symptoms of cocoa mineral deficiencies

Typical symptoms of various deficiencies, which mainly concern abnormalities of leaves, are well known and could help qualitatively diagnose imbalances in soil minerals. The most frequently observed are:

- **Nitrogen deficiency**: The leaves are small with a discoloration and yellowing of the leaf blade and ribs (Pictures p.57);

- **Boron deficiency:** The young leaves are abnormally elongated, often curled up, clutching at the edge and having yellow spots at the point of curvature. In the most advanced stage, the leaf tip is necrotic (Picture p.57);
- **Phosphorus deficiency:** Leaf tip becomes orange - brown, necrosis expand into yellow lined spots (Picture p.58);
- **Potassium deficiency:** A marginal olive-green discoloration of the leaf is observed, followed by necrosis (Picture p.58);
- **Magnesium deficiency:** Yellow discoloration of both sides of the midrib of the leaf (Picture p.58);
- **Calcium deficiency :** Peripheral drying of leaves with purple-orange and extending to orange-yellow spots with yellow border between the secondary veins (Picture p.58);
- **Iron deficiency :** Chlorosis due to iron deficiency is characterized by discoloration of the last emerged leaves. Presenting in the early stages a pale green, the leaves rapidly turn to yellowish green. Discoloration is interveinal with the ribs still green in colour (Picture p.58);
- **Zinc deficiency :** Very recognizable with the malformation of leaves being very narrow, elongated and often curved with very visible abnormal ribbing (Picture p.58).



Symptoms of nitrogen deficiency on coconut tree. There is a general yellowing of the leaves. At a more advanced stage, the crown has a small number of short, yellowish leaves.



A close-up of healthy leaflets (dark green) and deficient in nitrogen (golden yellow) with necrosis in the most advanced stage.

*Pictures R.Bourgoing*



Symptoms of potassium deficiency on coconut tree. Different shades of colors are observed on foliage but the youngest leaves are still green.

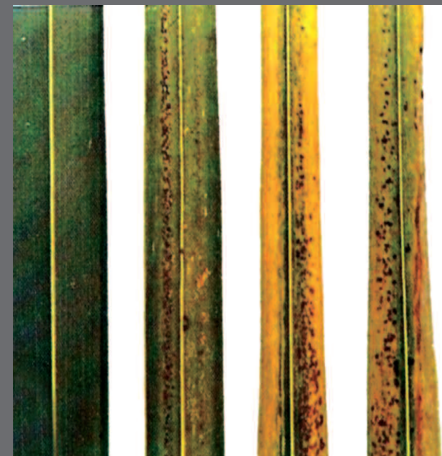

A close-up of healthy leaflets (dark green) and deficient in potassium (green to yellowish with small rusty spots); in the most advanced stage, the leaflet dries prematurely.



Symptoms of nitrogen deficiency on immature palm tree. A general yellowing of leaves is observed. The leaves emission is reduced and the overall growth of the tree is delayed. Trees production is affected.

Symptoms of potassium deficiency on palm tree. There is a yellowing of the middle of the crown (b), but younger leaves are still green. The deficiency is strongly manifested on the lower leaves (a); below is a close-up of the leaflets showing spotted discoloration, which could lead to complete drying of the leaflets.

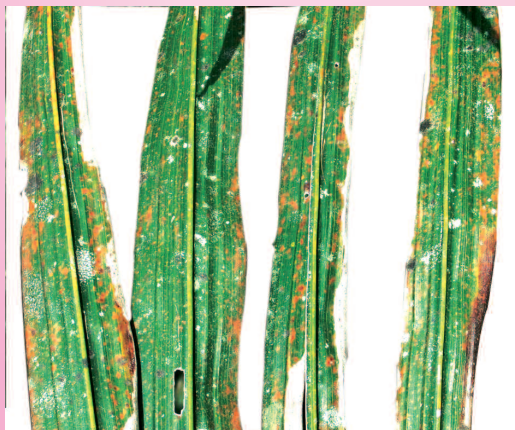

*Pictures  
R.Bourgoing*



Symptoms of magnesium deficiency on palm tree. The oldest leaves exposed to light get yellow; if the deficiency persists, necroses develop from the tip of the leaflets, their colour changes from orange-yellow to reddish brown.



Close-up of a palm frond. The leaf parts exposed to light get yellow. Also visible below on coconut leaflets (arrow).

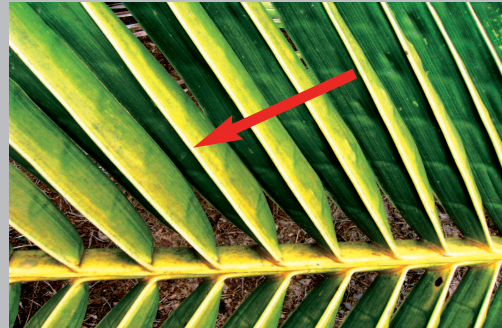

Symptoms of boron deficiency. There is a shortening of the newly emitted young leaves; here the blade is nonexistent and the palm frond withers.



Young palm tree showing an early shortening of young leaves, with curling and deformation of leaflets in bayonet-like shape (picture on the right).

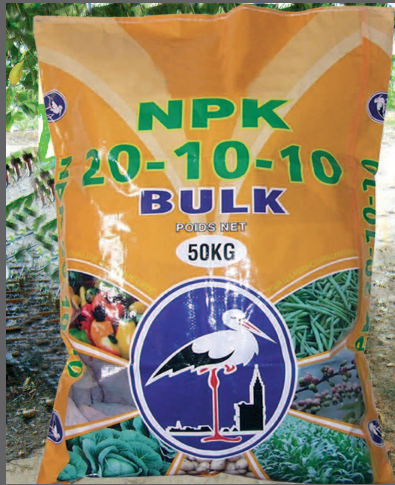

To avoid the appearance of mineral deficiencies, fertilizers must always be spread evenly over the entire surface of the circle

The quality of fertilizer applications will permit an optimum effect of the mineral elements provided; particularly respect the application periods and recommended dosages.



*Pictures R.Bourgoing*

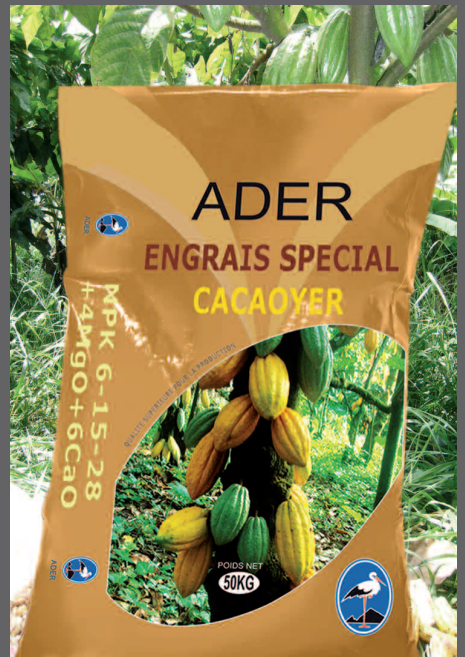





# Pests and diseases control

Some common pests and diseases of cocoa, palm, coconut trees and plantain, and their control

Symptoms	Name, causal agent, location, features	Treatment by farmer
<b>Cocoa: damages observed on pods</b>		
- The pods show one or more brown spots, stiff to the touch and covered with a creamy white spore coating.	<p><b>BLACK POD ROT</b> -<i>Phytophthora sp.</i></p> <p>Universal</p> <p>Dependent on the rainy season. Favoured in the plantations under-ventilated, if climate is very humid (Pictures p. 75, 76).</p>	<p>Prophylactic:</p> <ul style="list-style-type: none"> <li>- Sanitary harvest of contaminated pods and cherelles.</li> <li>- Reduction of atmospheric humidity by ventilation and pruning of cocoa crowns.</li> </ul> <p>Chemical:</p> <ul style="list-style-type: none"> <li>- Spraying at 21 day intervals of Copper hydroxide (<b>Kocide</b>) alternated with Cuprous oxide + Metalaxyl (<b>O.K.MIL 72 WP</b>) and (<b>Qualico 46 WP</b>) at the rate of 50 g commercial product for 15 litres of water</li> </ul>
- The pods are first stained with brown lesions, soft to the touch. They then become completely black.	<p><b>CHARCOAL POD ROT</b> - <i>Botryodiplodia theobroma</i></p> <p>Universal</p> <p>Sign of weakness as a result of insect bites or primary infection by <i>Phytophthora</i> spp. (Picture p.76)</p>	- Sanitary harvest
- The pods look normal, but in case of strong infestation, they seem to mature early. A careful observation shows the existence of fine perforations.	<p><b>POD BORERS</b> - <i>Conopomorpha cramerella</i></p> <p>South-East Asia, Pacific</p> <p>Pest favoured by the presence of host plant as the rambutan (<i>Mephelium</i>) and the cola (<i>Cola nitida</i>).</p>	<p>Farming systems:</p> <p>Elimination of cherelles and pods of more than 5 cm long during the low harvest period. Burn pods and cherelles (interruption of the cycle of the insect).</p>

<b>Symptoms</b>	<b>Name, causal agent, location, features</b>	<b>Treatment by farmer</b>
<b>Cocoa: damages observed on pods</b>		
<p>The pods are dotted with small blackish spots clearly individualized and indurated.</p>	<p style="text-align: center;"><b>MIRIDS</b></p> <p>- <i>Helopeltis</i></p> <p>Universal</p> <p>- <i>Sahlbergella sp.</i></p> <p style="text-align: center;">Africa (Pictures p.73, 74)</p>	<p>- Pruning of side shoots and maintenance of the crown.</p> <p>- 5 applications to 2-month intervals (March, May, July, September and November) with insecticide; alternate Acetamiprid + Cypermethrin (<b>Onex Super</b>) at the rate of 50 ml of commercial product for 15 litres of water or Imidaclopride (<b>Onex SC 30</b>). The November treatment may be carried out in with Chlorpyrifos-ethyl (<b>Pyriforce 600 EC</b>) at the rate of 50 ml of commercial product for 15 litres of water or Imidacloprid + Bifentrin (<b>Kohinor Star</b>)</p>
<b>Cocoa: damages observed on the vegetative system</b>		
<p>- The whole foliage is deteriorated or many tips of branches are leafless and often dried out. Appearance of side shoots at the base of the tree. All the foliage dries out from top to bottom.</p>	<p style="text-align: center;"><b>CALONECTRIA TRACHEOMYCOSIS</b></p> <p>- <i>Calonectria sp.</i> - <i>Colletotrichum sp.</i></p> <p>Universal</p> <p>Almost always resulting from a mirid attack. (Pictures p. 77).</p>	<p>- Extraction or poisoning of stumps</p> <p>- Careful uprooting of the trees with all their roots</p>
<p>- The foliage has all dried at once and the leaves remain attached. No living side shoots at the base of the tree. Vertical slots and cracks can appear at the level of the bark of the collar. Then the disease spreads by spots.</p>	<p style="text-align: center;"><b>“ROOT” ROT</b></p> <p>- <i>Armillariella mellea</i> - <i>Fomes sp</i></p> <p>Universal</p> <p>Occur mostly in the plantations where the stumps of tall trees have not been uprooted or poisoned (Picture p.77).</p>	<p>- Removal of sick parts;</p> <p>- Eventual replacement of the tree through the development of a healthy shoot</p>

<b>Symptoms</b>	<b>Name, causal agent, location, features</b>	<b>Treatment by farmer</b>
<b>Cocoa: damages observed on the vegetative system</b>		
<p>-Part of the foliage is damaged. The leaves dry out but do not drop. Partial death of the tree by disease progression from bottom to top.</p>	<p><b>VERTICILLIUM TRACHEOMYCOSIS</b> - <i>Verticillium sp.</i> Universal Favored by intense evapotranspiration.</p>	<p>- Removal of sick parts.  - Eventual replacement of the tree through the development of a healthy shoot.</p>
<b>Cocoa: damages observed on branches</b>		
<p>- Numerous dried branches still bearing a few dead leaves. The mature wood presents more or less broken depressions.</p>	<p><b>MIRIDS</b> - <i>Helopeltis</i> - <i>Sahlbergella sp.</i> Universal  The desiccation and death of branches are widely due to a secondary tracheomycosis introduced in the wood through the bites of the mirid. (Pictures p.74)</p>	<p>Pruning of side shoots. - Maintenance of the crown - 5 applications at 2-month intervals (March, May, July, September, November) of the insecticide Acetamiprid + Cypermethrin (<b>Onex Super</b>) at the rate of 50 ml of commercial product for 15 litres of water or Imidacloprid (<b>Onex 30 SC</b>). Treatment of November can be accomplished with Chlorpyrifos-ethyl (<b>Pyriforce 600 EC</b>) at the rate of 50 ml of commercial product for 15 litres of water.</p>
<p>- Branches dried, isolated or in small groups still carrying their dead leaves - Presence of circular holes leaving out sawdust</p>	<p><b>STEM BORERS and WOOD MINING CATERPILLARS</b> - <i>Tragocephala sp.</i> Universal Common on seedlings exposed to sunlight.</p>	<p>- Pruning of dead branches.  - Maintenance of the plantation.</p>
<p>- Presence of numerous white "flakes" of fluffy appearance attached to the ends of young shoots or on flowers and floral cushions. Damage sometimes very important on seedlings exposed to full light.</p>	<p><b>PSYLLIDS</b> - <i>Tyora tessmanni</i>  Africa  Particularly affects leaf outbreaks (nurseries and field). (Picture p.73)</p>	<p>- Insecticides: Chlorpyrifos-ethyl (Pyriforce 600 EC) at the rate of 50 ml of commercial product for 15 litres of water, alternated with Acetamiprid + Cypermethrin (<b>Onex Super</b>) at the rate of 50 ml of commercial product for 15 litres of water, or Imidacloprid (<b>Onex SC 30</b>). A monthly application the first year; treatments for mirid control: 5 passes yearly starting from the 2nd year, will allow controlling psyllids and other foliage pests that appear at the emission of 1st cocoa flushes at the onset of rainy season (March).</p>

<b>Symptoms</b>	<b>Name, causal agent, location, features</b>	<b>Treatment by farmer</b>
<b>Cocoa: leaf damages observed</b>		
<p>- Leaves discoloration in spots, then general yellowing and rust hue before dropping.</p>	<p style="text-align: center;"><b>THRIPS</b></p> <p>- <i>Solenothrips rubrocinctus</i></p> <p>Universal</p> <p>Frequent during water stress period.</p>	<p>Insecticide: Imidacloprid (<b>Onex SC 30</b>) at the rate of 50 ml of commercial product for 15 litres of water. Chlorpyrifos-ethyl (<b>Pyriforce 600 EC</b>) at the rate of 50 ml of commercial product for 15 litres of water.</p>
<b>Plantain: damages observed on the bulb and root system</b>		
<p>- Numerous galleries dug into the bulb and recognizable by deposits of sawdust that mark it. The bulb, weakened, results in the rapid fall of the plantain banana that produces only a small bunch.</p>	<p style="text-align: center;"><b>WEEVIL</b></p> <p>- <i>Cosmopolites sordidus</i></p> <p>Universal</p>	<p>- Insecticide: Ethoprophos (<b>Pacom 20 G</b>) 25 g/plant/application, or Oxamyl (<b>Vydate 10 G</b>) 40 g/plant/application starting at planting and then twice in the first cycle and the subsequent cycles.</p>
<p>- Roots parasite that causes lesions quickly invaded by fungi, bacteria, resulting in a general weakening of the plant and the production of small bunches.</p>	<p style="text-align: center;"><b>NEMATODES</b></p> <p>- <i>Radopholus similis</i></p> <p>Universal</p>	<p>- Nematicide: Oxamyl (<b>Vydate 10 G</b>) or Terbufos (<b>Control G 10</b>) 30 g / plant / application and 3 times per cycle.</p>
<b>Oil Palm - Coconut: defoliators</b>		
<p>- More or less complete defoliation of the leaflets up to almost 100%, leaving only the midrib.</p>	<p style="text-align: center;"><b>LEPIDOPTERANS</b></p> <p>- <i>Hesperidae</i></p> <p>West Africa</p> <p>Caterpillar, up to 5 cm long, living isolated in the shelter of a cone (leaflet edges brought together by a silk thread).</p>	<p>- Insecticide: Spraying of Dimethoate (<b>Dimex 400 EC</b>) at the rate of 50 ml of commercial product for 15 litres of water.</p>

<b>Symptoms</b>	<b>Name, causal agent, location, features</b>	<b>Treatment by farmer</b>
<b>Oil palm - Coconut: defoliators</b>		
<p>- Upper epidermis of the leaflets blistered and dried; galleries between the two epidermis.</p>	<p style="text-align: center;"><b>COLEOPTERA</b></p> <p>- <i>Chrysomelidae hispanae</i> - <i>Coelaenomenodera minuta</i></p> <p>West Africa, Cameroon.</p> <p>Larva up to 6.5 mm long, flat. The adult lives on the underside of leaves where it digs small furrows. (Pictures p.81)</p>	<p>Insecticide: Three applications at 15 day intervals, Acetamiprid + Cypermethrin (<b>Onex Super</b>) at the rate of 50 ml of commercial product for 15 litres of water, or Cypermethrin (<b>Cygnose 50 EC</b>) at the rate of 40 ml of commercial product for 15 litres of water.</p>
<p>- Cut up large pieces of leaflets, sometimes in their middle.</p>	<p style="text-align: center;"><b>ORTHOPTERA</b></p> <p>- <i>Acrididae</i> - <i>Zonocerus variegatus</i></p> <p>West Africa</p> <p>Damage to young plants in the early stages that live in colonies. Grow abundantly on the tufts of <i>Chromolaena</i>.</p>	<p>Insecticide: Cypermethrin (<b>Cygnose 200 EC</b>) at the rate of 50 ml of commercial product for 15 litres of water, or Dimethoate (<b>Dimex 400 EC</b>) with the same rate.</p>
<p>- During a strong infestation almost all the leaves of the coconut tree that turn yellow can be affected. In case of strong infestation, insects are side by side, with the shields forming a crust almost continuous on the underside of infested palms.</p>	<p style="text-align: center;"><b>COLEOPTERA</b></p> <p>- <i>Aspidiotus destructor</i></p> <p>Universal</p> <p>Transparent coconut mealy bug; a violent attack can occur due to unfavourable weather or agronomic conditions (Pictures p.82).</p>	<p>Usually no treatment is necessary to control <i>Aspidiotus</i>; several ladybird species are able to control the mealy bug populations.</p>

<b>Symptoms</b>	<b>Name, causal agent, location, features</b>	<b>Treatment by farmer</b>
<b>Oil palm - Coconut: borers</b>		
<p>- Galleries at the foot of the trees climbing towards the meristem (on young plants up to 2 years)</p>	<p style="text-align: center;"><b>COLEOPTERA</b></p> <p>- <i>Scarabeidae</i> - <i>Oryctes monoceros</i></p> <p>Africa</p> <p>(Pictures p.78)</p>	<p><u>Prevention:</u> Eliminate wood after felling by exporting or by burning. One can also cover the wood with a cover crop.</p> <p><u>Cure:</u> By manual harvesting of adults on palm trees using a wire hook-shaped, and larvae in the egg-lay shelters. Treat with Oxamyl (<b>Vydate 10 G</b>) spread in the leaves axils.</p>
<p>- Big white "worm" in living tissues on the wounded palm trees.</p>	<p style="text-align: center;"><b>COLEOPTERA</b></p> <p>- <i>Rhynchophorus phoenicis</i></p> <p>Africa</p> <p>(Picture p.78)</p>	<p>Avoid injuries.</p> <p>- Cure: Extract the larvae from affected tissues and treat with a solution of dimethoate (<b>Dimex 400 EC</b>) at the rate of 50 ml of commercial product for 15 litres of water. Refill the wounds with a vegetal tar.</p>
<b>Oil palm - coconut: diseases</b>		
<p>- Small yellowish spots on the top or on both sides of the midrib of the leaf</p> <p>- Small yellowish spots on the spear or both sides of the midrib of the leaf 1.</p> <p>- Stop of the growth.</p>	<p style="text-align: center;"><b>DRY BUD ROT</b></p> <p>- Causal agent unknown</p> <p>Africa</p> <p>Nursery and planting year disease. Oily stains in the root set.</p>	<p>- Prevention: see Blast.</p>

<b>Symptoms</b>	<b>Name, causal agent, location, features</b>	<b>Treatment by farmer</b>
<b>Oil palm - coconut: diseases</b>		
<p>- The top and the root cortex rot on palm tree, orange cross section of the meristem.</p>	<p style="text-align: center;"><b>BLAST</b></p> <p>- <i>Mycoplasma</i></p> <p>Africa</p> <p>Deadly disease in nurseries, which may also appearance in the first year of planting. (Picture p. 83)</p>	<p>-<u>Prevention</u>: In nurseries, application of Oxamyl (<b>Vydate 10 G</b>) t the rate of 5 g of commercial product per plant.</p>
<p>-Orange-brown speckles on older leaves, then drying of the tips and edges of the leaflets blade.</p>	<p style="text-align: center;"><b>CERCOSPORIOSIS</b></p> <p>- <i>Cercospora elaeidis</i></p> <p>Africa</p> <p>Depressive effect on growth of young palm seedlings in nursery, but without important economic adverse effects in plantation (Picture p. 82).</p>	<p>- Fungicide: Mancozeb or Maneb in nursery (<b>Mancozan blue</b>) or (<b>Trimaneb 80 WP</b>) at the rate of 100 g of commercial product for 15 litres of water.</p>
<p>- Presence of brown leaf spots usually elongated, first isolated then coalescing. As the parasite spreads on the leaf blade, the centre of the spot gets necrotic and turns gray and brittle, the leaflet and the leaf take a ragged appearance.</p>	<p style="text-align: center;"><b>BLIGHT</b></p> <p>- <i>Helminthosporium halodes</i></p> <p><i>Universal</i></p> <p>The parasite can cause a significant reduction in leaf area causing growth retardation of seedlings in the nursery and the field (Picture p. 82).</p>	<p>-Fungicide: In the nursery, application of Chlorothalonyl + Dimetomorphe (<b>Sphinx Star</b>) at the rate of 50 g of commercial product for 15 litres of water. Weekly treatment in nursery.</p>

<i>Symptoms</i>	<i>Name, causal agent, location, features</i>	<i>Treatment by farmer</i>
<b><i>Oil palm - coconut: diseases</i></b>		
<p>- Oily spots on leaflets located at the base of young leaves, yellowing of young leaves, and progressive drying of older leaves remaining erect, tree death.</p>	<p style="text-align: center;"><b>DRY BUD ROT</b></p> <p>Unknown</p> <p>Africa</p> <p>Deadly disease that can occur from 3 to 4 years.</p>	<p>Eradication of sick trees and destruction of tree trunks and stumps.</p>





Attack on cocoa by insects (Psyllids) in the first year always cause major damages with the destruction of the terminal bud that causes stunted growth and malformation of the crown. In the picture, the attack touches the plagiotropic branches on a mature tree.

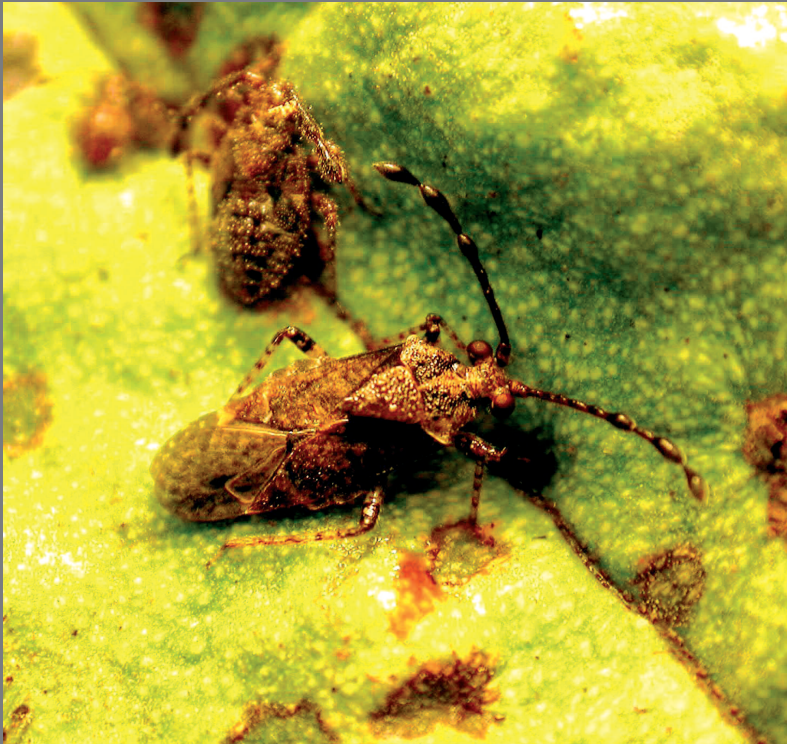

Cocoa tree capsids  
*Sahlbergella*  
*singularis*

Pictures R.Babin



Photos & texte de R.Babin

### Damages of *Sahlbergella singularis* on cocoa tree:

**A:** stings on a young pod creating cracks in the cortex and deformation of the fruit (the fruit was turned, showing where it was stung at the contact point between the pod and the trunk)

**B:** blights on a semi-lignified branch

**C:** blights on the bark of a branch,

**D:** drying of the leaves due to bites on the young shoots,

**E:** “die-back” due to an infection by a parasitic fungus (side shoots are visible at the foot of the trees).



Damages by *Phytophthora megakarya*

Picture R.Babin



Recent attack by *Phytophthora megakarya*

Picture M. Ten Hoopen



Various symptoms  
of rot on cocoa  
pods:

Left and right, black pod rot caused by *Phytophthora sp.*



Charcoal pod rot caused by  
*Botryodiplodia theobromae*



Pod deformed by *moniliosis*  
disease



Symptoms of attack by "die back", partial drying of the leaves of the crown; a branch remains green (see arrow). After pruning of dead wood (right), new shoots may develop along the trunk or at its base. To favour the striking of the tree, cut off the trunk 70 cm above soil level and before full drying of the foliage. This disease often leads to the death of the tree.



Young cacao tree attacked by rots, the root system is attained and is no longer functional; the tree dries out completely in a few weeks.



Cocoa tree suffering from drought inducing general yellowing of the foliage. At last, the leaves dry up and drop. Most of the time the trees regenerate their foliage at the beginning of the rainy season.



A

**Some important pests on oil palm and coconut trees:**

**A:** Adult *Oryctes* sp. and the larva.

**B:** Larva of *Rhynchophorus* sp.

**C:** Adult of *Rhynchophorus* sp.

**D:** Caterpillar of *Setothosea asigna*

*Pictures R.Desmier de Chesnon*



B



C



*Picture R.Babin*

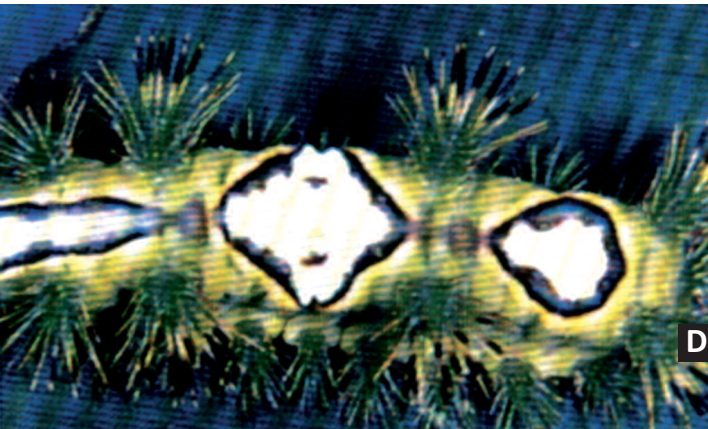

D

Louis Dreyfus  
Commodities

For an efficient  
and profitable  
**protection**



[www.ldcom.com](http://www.ldcom.com)



Douala - Z.I de Bonabéri B.P : 2368 - Cameroun  
Tél : +[237] 33 39 91 16 - Fax : +[237] 33 39 16 39  
Yaoundé - Tél : +[237] 22 23 59 04 - Fax : +[237] 22 22 34 23

# Louis Dreyfus Commodities

Everyone with  
a sprayer for  
**good COCOA**



[www.ldcom.com](http://www.ldcom.com)

Douala - Z.I. de Bonabéri B.P: 2368 - Cameroun  
Tél : +(237) 33 39 91 16 - Fax : +(237) 33 39 16 39  
Yaoundé - Tél : +(237) 22 23 59 04 - Fax : +(237) 22 22 34 23



## Some defoliators on oil palm and coconut tree:

A: larva of *Parasa lepida*. (Photo by R. Desmier de Chesnon)

B: larva of *Thoesa asigna*. (Photo by R. Desmier de Chesnon)

C: Caterpillar of *Setothosea asigna* affected by milky disease.

D: Adult of *Coelaenomenodera minuta*. (D. Mariau)

E: Larval galleries of *Coelaenomenodera minuta*. (D. Mariau)

F: Caterpillar of *Setora nitens*. (R. Desmier de Chesnon)

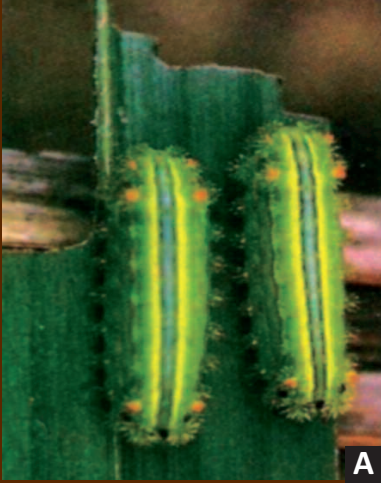

A



B



C



D



E

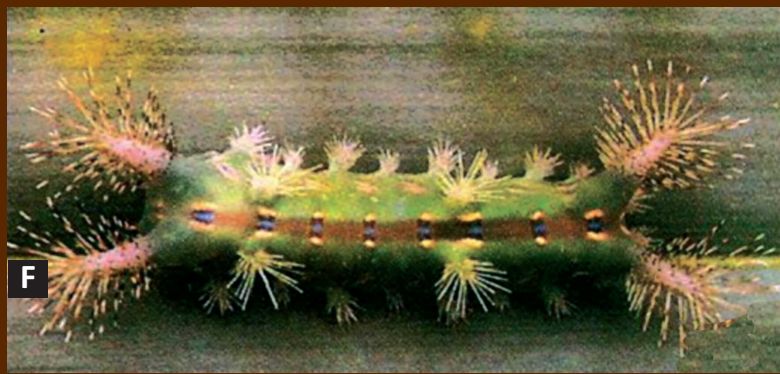

F

Other common diseases or insects that may affect the foliage of oil palm or coconut tree:

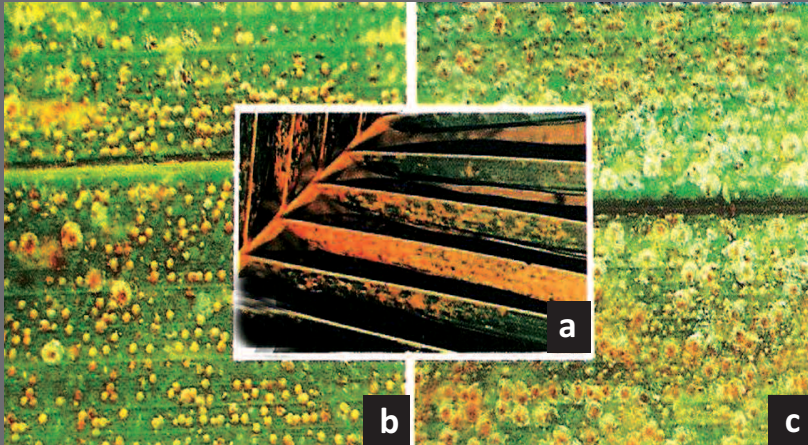

Symptoms of *Aspidiotus destructor* attack: a) yellow spots on the surface of the leaflets of coconut tree, b), c) *Aspidiotus* feeding on the underside of a leaflet.

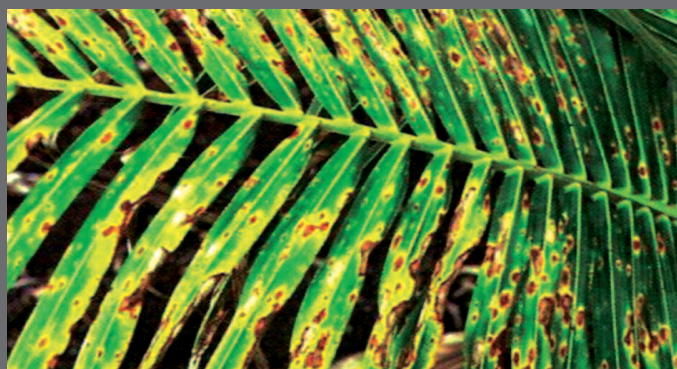

*Helminthosporium* damages on a palm frond of coconut tree. (J.-L. Renard)

Cercosporiosis on a leaf of an oil palm tree seedling.

*Astegopterix nipae* feeding on a leaflet of an adult coconut tree.

Pictures R..Desmier  
de chesnon





Blast attack on young oil palm tree; the seedling dies quickly.

*Photo I.R.H.O*



Farmer's weekly monitoring of the sanitary status of the nursery.

*Picture R.Bourgoing*



Insecticide treatment on young cocoa tree using a knapsack sprayer; note that the quality of the spraying is very essential for a good and efficient treatment.

*Pictures R.Bourgoing*

From the age of 3 years, the height of trees requires the use of an atomizer to ensure efficient phytosanitary treatments.





## Management of trees

A well balanced development of the crowns will permit a better production distribution on the trees, facilitate harvesting and improve the health status of the farm as well as the efficacy of chemical treatments.

### Cocoa

- **Formation of the crown** : Psyllid or insect attacks in the first and second year of planting usually cause the death of the terminal bud; several auxiliary buds will then give rise to 3 or 4 new orthotropic shoots that will in turn give rise to as many crowns if all these stems are conserved.

**While inspecting the plants during this period, it will be necessary to select the most vigorous stem and remove all others.** Do this when the selected stem has reached the size of 20 to 25 cm; at this stage the other stems are easily detached with the touch of a finger. **Then the main stem forms a jorquette from which four or five primary branches appear** (the jorquette generally forms at about the height of a person chest).

To avoid this damage, which delays the formation of the jorquette and causes an architectural disequilibrium of the tree often forming the crown at over 2 m height it is advisable to respect phytosanitary recommendations (see "Phytosanitary treatments").

- **Removal of side shoots or chupons**: Regularly remove chupons that develop in the crown or stem; equally remove the dead stems and branches during this operation ([Picture p.88](#)).

- **Pruning for cocoa production** : Concerning cocoa, pruning, as from the third year, is limited to thinning the foliage by removal of secondary or tertiary branches that enter inside the crown. Branches drooping to the ground are also eliminated.

Avoid trees to rise too high or to nest one within the other by cutting the end of side branches if necessary. Use a good tool such as a pruning hook to ensure a clean pruning and when the height of the tree does not allow the use of secateurs (Pictures p.89, 90).

➤ When the crown is too low cut or tip the branches to raise the crown allowing air to circulate thus avoiding development of funguses.

➤ The crown is very high and the pods up difficult to harvest; just do this: (1) cut the chupons when they become very thick, (2) cut the branches growing vigorously upward, (3) tip and lop off the highest branches, (4) stump the tree to reconstruct the tree.

➤ When the crown is very closed with many branches crossing, diseases may occur and the light does not pass through the canopy to stimulate flower cushions and produce fruits. To open the crown, the intertwined branches must be cut, eliminating also the low branches that do not receive light.

➤ Branches intertwined with those of other trees hinder tree management, produce a lot of shade and humidity that foster disease, and reduce flowering. To fix this problem we stand halfway between the tree we are pruning and each one of its neighboring trees. We look up and tip and lop off all the branches that come onto and pass through the midpoint between the two trees, going full circle. We do this with each tree.

➤ Balanced and unbalanced crowns: the crown of cocoa trees naturally develop balanced with branches growing in all directions. During the life of the tree the crown can become unbalanced because it loses one or more primary branches due to

diseases or because the branch of another tree or a plantain plant falls on it. To balance the crown, branches must be allowed to grow in the open part so that the tree occupies all of its living space (Pictures p.89, 90).

## Oil palm

- **Castration of inflorescences** : The technique of castration (or removal) of inflorescences and young palm bunches consists of eliminating the first inflorescences or bunches produced at a frequency of one round per month until the end of the 2<sup>nd</sup> year or the 30<sup>th</sup> month after planting. This is to facilitate the vegetative growth of young palms trees. Use the appropriate tool to avoid hurting the trees during this operation (Picture p.91).

- **Sanitary harvest** : Sanitary harvest is the operation of cleaning the oil palm tree crown before the start of the main harvest. It involves cutting only the dry palm fronds and, if necessary, removing the very all first and already old and rotten bunches.

- **Pruning** : From the fourth or fifth year, cutting of bunches is accompanied by that of 1 or 2 embarrassing palm fronds depending on the number of bunches to be harvested. Every year a variable number of palm fronds remain below the crown. A special operation called pruning consists of removing these palm fronds. Thereafter, they are cut up into 3 equal parts and arranged in heaps between palm trees along the planting rows.

- Level of pruning :

Up to 4 to 5 years: pruning is done by cutting only the dry leaves.  
From 5 to 6 years: 2 palm fronds are left under the ripe or immature bunch, and after 15 years only a single palm frond is left. Keep in mind that a too severe pruning will result in a production decrease.

- Tools needed:

Cutlass and chisel until 5 to 6 years.  
Chisel and sickle beyond.



The chupons/suckers growing on the trunk or branches of the crown (arrow) must be regularly eliminated while still young, just with a touch of the finger.

*Pictures R.Bourgoing*

Uncontrolled development of the crown will cause an imbalance in the tree; too dense foliage may induce a major production loss with black pod rot disease. Phytosanitary treatments become less effective and pods harvesting difficult.

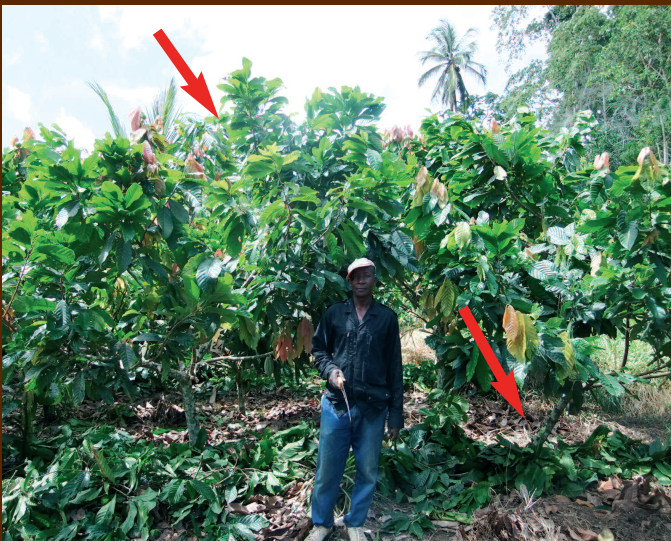

"Rebalancing the trees" is often required from the age of 3-4 years to limit the growth of branches that turn too high (left arrow) and to permit the consolidation of strongly inclined trunks (right arrow) by shortening the branches on the side where the tree inclines.



## The pruning of production of a cocoa tree:

**A** : Tools used to prune the cocoa tree; pole pruners (long rod that has pruning shears and a curved saw at the end), curved pruning saw, pruning shears and “tiers point” file.

**B** : Young cocoa tree requiring pruning to permit light get into the crown.

**C** : The branches (arrow) developing inwards are removed to allow the easy entry of light and thus promote good flowering.

**D** : Use a pole pruners to limit tree height between 3 and 4 meters.

**E** : Tools should always be kept sharp to make clean and easy cuts.

**F** : Appearance of the cocoa tree after pruning carry out one month after the start of the rainy season.



Pictures R.Bourgoing





After pruning exercise, the branches and leaves removed are assembled on the cocoa planting row to free the strip of cover crop (*Brachiaria*).



Same tree as on the picture above (left corner) but 5 months after pruning. Note the high production of pods; tree age: 4 years.



After cutting up the branches, leaf litter is well arranged on the planting row; this thick mulch will permit weed control while maintaining soil moisture.



Production start of the palm tree at 4 years; after castration or removal of inflorescences up to the third year, the weight of the first bunches can reach 5 to 6 kg.

Below is the diagram of the tool used to carry out castration of inflorescences that have to be removed each month and before the opening of the spathe.

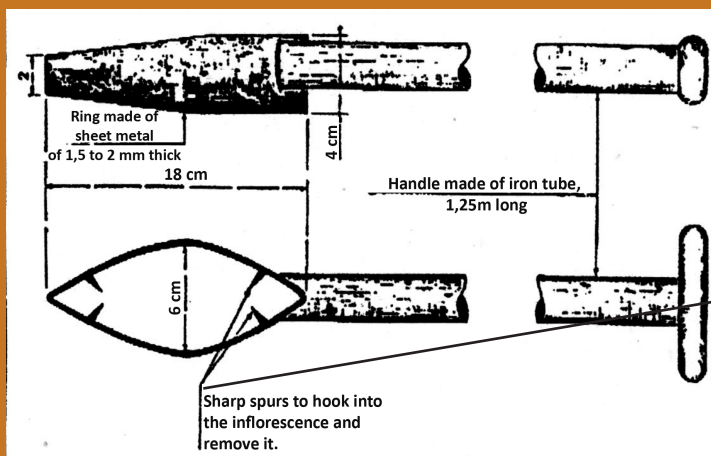

Flattened lense - shaped ring with spurs; once helved, it allows easy removal of young inflorescences.



## Harvesting of cocoa

Harvesting the cocoa pods should be done at regular intervals of 10 to 15 days. At harvest, it is important not hurt the flower cushions that will produce flowers and fruits of the following harvests; injuries that could allow the penetration of parasitic fungi in the tissues of the tree.

### Harvesting tools

In the young age or for pods at easy reach use secateurs, as soon as the trees grow tall use the sharp cocoa hook on a stick to get a net section of the stalk.

### Ripeness criteria

The pod changes colour, turning green to yellow or red to orange. Harvesting should be done as soon as the pods are ripe. It is essential that the pods do not become overripe as they are more likely to become infected with diseases (rots) and the beans inside the overripe pods will germinate and vulnerable to rodents. It is equally not to harvest unripe pods. The beans inside unripe pods will not be ready for fermenting and produce low quality cocoa (Photo p.94).

### Cocoa pod breaking

Pod breaking should be conducted in an appropriate manner to

avoid damage and contamination of the beans, and should be carried out simultaneously after harvesting each tree. The skins are spread round the cocoa, and these crop residues after decomposition, permits a partial restoration of nutrients taken up by the plant and with the addition of organic matter will be beneficial for future production while improving the sustainability of this cropping system (picture p.94).

## Transportation of beans

The beans are put in bags after breaking the pods and transported to the fermentation point (picture p.94).



Harvesting of ripe pods must be performed every 2 to 3 weeks; picking is done by sharp cutting of the peduncle.

*Photos R. Bourgoing*



The harvested pods are opened under each tree respectively; the husks are returned to the tree and spread over the ring.

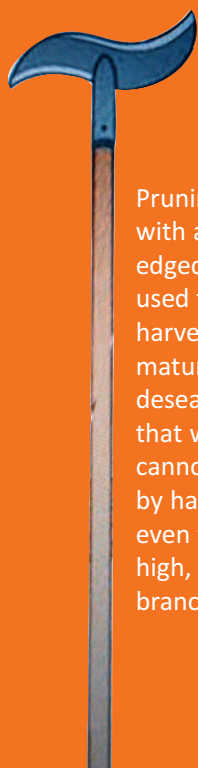

Pruning pole with a double-edged blade used to harvest mature or diseased fruits that we cannot reach by hand and even to cut high, thin branches.



Transport of beans to the processing site for fermentation and drying.



# rocessing cocoa beans

The quality of "cocoa" is based on the conduct of two important operations: fermentation, which will allow development of "precursors" of the chocolate flavour and drying which reduces the water content of fermented beans at a rate of 6 to 7%.

## Fermentation

### - Duration

4 to 6 days, depends on climatic conditions, the mass of cocoa beans under fermentation and the method used.

### - Methods

In heaps : The beans are placed on a carpet of banana leaves and covered with the same leaves. On the ground under banana leaves, a carpet of branches will be spread to permit the flow of cocoa juice.

Use of woven baskets : Daily turning or mixing is done by pouring the beans from one basket to another (Picture p.97).

In a box : The volume of the box is very variable and should be adapted to the needs of the farmer (Pictures p.97, 98). Turning or mixing is also done by transferring the beans from one box into another.

### - Ending fermentation

Several typical characteristics must be taken into consideration:

- the swelling of the beans;
- the smell of the mass;

- the brown colour of the cotyledons;
- the drop in temperature.

## Open air drying

Sun drying is the simplest and the most frequently used in most producing countries. Climatic conditions must be favourable and drying usually requires 8 - 15 days of exposure of the beans.

### - **Drying on mats**

The beans are spread in thin layers on mats placed on the floor. After direct natural sunlight drying of cocoa (3-4 days), it is laid on a sheet of black plastic, which is lying on the mat. Every night or when rain falls, roll the plastic sheet with the cocoa which ensures protection and repels moisture. With this method, we good quality drying in about 10 days (Pictures p.99).

### - **Another method of drying**

It includes the “autobus» dryer whose shelter is often made of wood and covered with mats or roof sheets. The band for drying the beans are made of mats stretched over a wooden frame, the band can be quickly slipped under the roof by sliding on wooden ramps set up at different heights (Picture p. 99).





## Processing of marketable cocoa:

Beans Fermentation in a box covered with a jute bag.  
Beans stirring every 2 days; duration of fermentation: 5 to 6 days

Wooden fermentation box; size: 70 x 70 x 70 cm, the bottom of the box is drilled with holes to allow the juice to flow.  
Capacity of a box: 90 to 100 kg of beans.

*pictures R.Bourgoing*

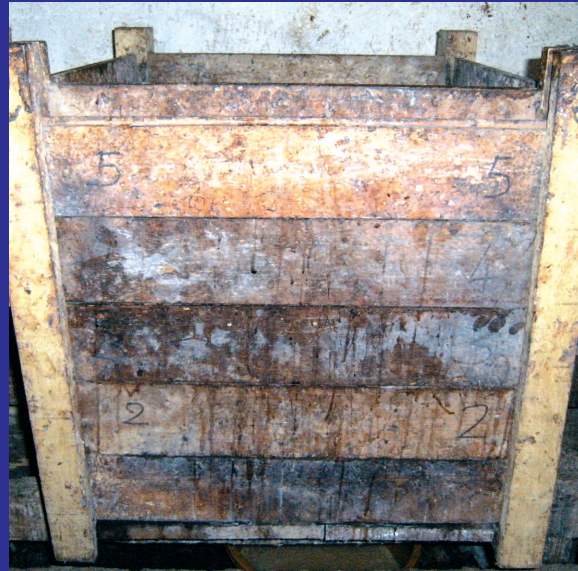

Processing marketable cocoa: fermentation in baskets

*Picture G. Mossu*

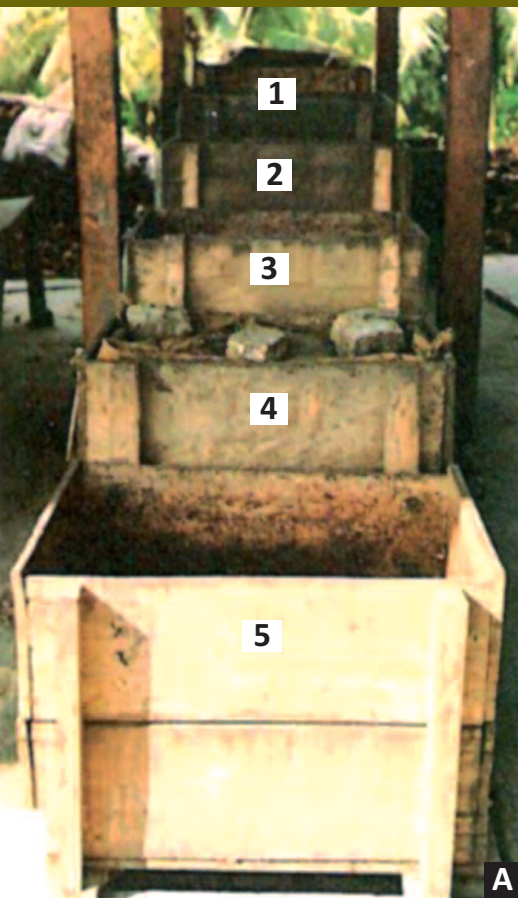

## Processing higher grade marketable cocoa:

**A:** Method for fermentation in series, filling box 1 on the 1st day; 24 hours later, transfer of beans into box 2, and then 3, 4 and 5 until the 5th day.

**B:** Cover of beans with a jute bag to maintain a good temperature.

**C:** End of fermentation phase; note the good brown-red colour.

**D:** Drying of beans in a thin layer, 3-4 cm, on a wooden platform covered with a plastic tarpaulin, turning 4 times per day. Duration: 6-7 days.



*Pictures R.Bourgoing*



Drying of beans on bamboo mat after fermentation, with regular stirring for a homogeneous drying.

*Picture R.Nsouga Amougou*



Drying on black plastic sheet of tarpaulin deployed onto a cemented area; the heat absorbed by the plastic will allow a good drying in 10 days.

*Picture R.Bourgoing*

# Harvesting of palm bunches



Bunches must be harvested at full maturity for the production of good quality oil. The organisation of the harvest site and of fruits transportation to the processing centre must be well adapted.

## Ripeness criteria of bunches

- **Ripe bunches** : More than one palm nut naturally fall off the bunch (Picture p.104).

- **Unripe bunches**: Any bunches whose maturity is less than the above standard.

For coconut, a bunch is considered ripe when, shaking one of the nuts, the water contained inside produces a splashing sound.

To ensure a good quality of oil palm harvest, it is necessary to plan 2 to 4 harvest rounds monthly during sustained production period, and 1 to 2 rounds when it is lower.

## Harvesting tools

- **Cutlass, narrow chisel** 7 cm (young trees).

- **Wide chisel**, 15 cm (at the age of 5- 6 years).

- **Sickles**, as soon as the trees are 2 m high. Also called "Malayan knife" this tool consists of a curved blade attached to a handle of variable length, usually made up of aluminium tube (Pictures p.101).

All harvesting tools must be sharpened several times daily with a sharpening stone to facilitate cutting and reduce the painfulness of the operation. The first sharpening of the sickle must be performed on both sides with a triangular file.

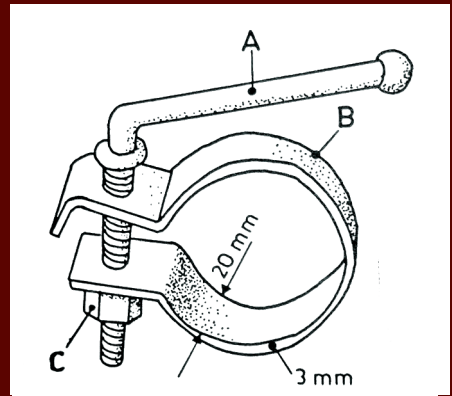

- A: Threaded lever
- B: Steel clip
- C: Hexagonal headed threaded nut welded to clip.

**Schematic diagrams for assembling the harvesting tool:**

A farmer holding a sickle mounted into aluminium tubes; note that the sickle handle has been reinforced by a piece of metal welded to it (arrow).

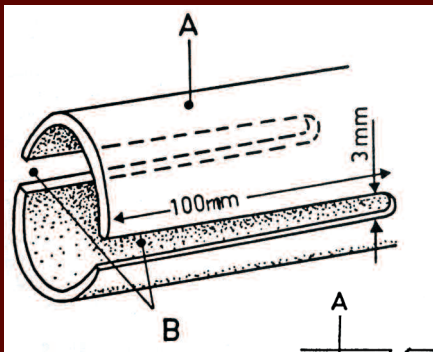

- A: Outer new aluminium tube, L= 6 m
- B: Slits sawn into tube

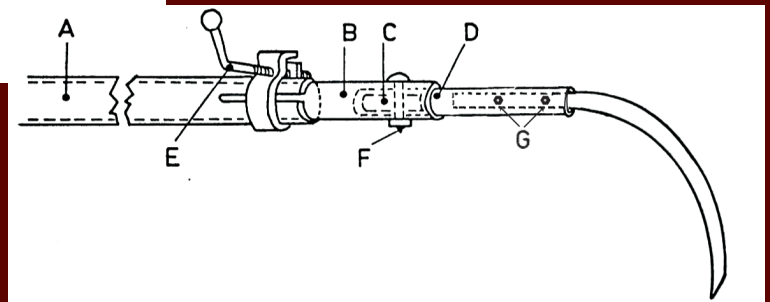

- A: Outer new aluminium tube, B: Inner new alu. tube, C: wooden peg
- D: Ordinary alu. pipe, E: Threaded lever, F: Round headed mild steel rivet,
- G: Two round headed mild steel pin.

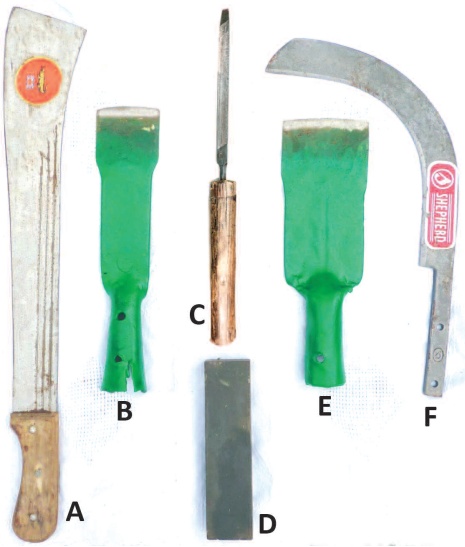

Use appropriate tools for easy harvest:

- A: Cutlass (steel made, imported)
- B: Chisel 7 cm wide (locally made)
- C: Tiers point file
- D: Triangular file
- E: Chisel 13 -15 cm wide (locally made)
- F: Sickle, a tool usually found in hardware ; length from 52 to 54 cm, width 21 to 25 cm, handle 21 cm long (steel made, imported ).

## Assembling harvested fruits

The harvested palm bunches are assembled at the foot of the palm trees until the palm nuts become detachable. The picking off of the nuts, done on the farm, will be carried out 5-6 days after harvesting. The nuts are then transported to the oil mill for processing the same day. After picking off of the nuts, the cobs are spread around the palm trees as organic and mineral fertilizer; the cobs are an important source of potassium and other mineral elements (Pictures below) .



Picking off the palm nuts 5-6 days after harvesting



Decomposing palm cobs over the ring (a). The numerous galleries and small earth worm casts round the heaps of organic matter show the intensification of soil biological activity (b).



Production start at the age of 4 years for well managed palm trees intercropped with cocoa trees.



*Photos R. Bourgoing*



With the variety "Local Coconut Tall", production will start around year 6. In case of good use of mass selection, the level of production of coconut trees could exceed 100 nuts/tree/year.



**A**

## Processing palm tree bunches:

**A:** Mature palm bunch with 2 released nuts.

**B:** Operation of boiling the nuts before oil extraction.

**C:** Cooking drums and palm nuts pressing making use of a motorised screw press.

**D:** Oil extraction using a manual screw press.



**B**



**C**



**D**





The use of a manual screw press may require four people for easy operation.



Such a motorised screw press has a processing capacity of 200 to 300 kgs of palm nuts per hour.



FOSTANG made equipment for picking off the nuts from bunches.



Decanter used for separating oil from water and residues.



Sterilizer used for cooking the nuts before pressing .

Various equipments used for semi-industrial oil palm processing.



A general view of a small scale oil palm industrial unit with a processing capacity of 3,500 to 4,000 litres oil per day.



## Production forecasts

These forecasts are made for a 1.0-hectare plot set up and managed according to recommended technical standards and established on a deep and well-structured soil.

### Production forecast for a one hectare cocoa-palm plot (kg).

Year	Cocoa tree (cocoa merchant)	Plantain	Oil palm (bunches)
0 (plantation)	0	0	0
1	0	3 000	0
2	20	4 500	0
3	100	500	0
4	700	0	3 000
5	900	0	4 000
6	1 000	0	6 000
7	1 000	0	8 000
8	1 000	0	10 000
9	1 000	0	12 000
10	1 000	0	13 000
11	1 000	0	13 000
12	1 000	0	13 000
13	1 000	0	13 000
14	1 000	0	13 000
15 and beyond	1 000	0	13 000

*These productions are made by taking into account the optimum density for each crop.*

*For oil production using a manual screw press, an extraction rate of 18% over the weight of treated bunches is considered.*

## Production forecast for a one hectare cocoa-coconut plot (kg)

Year	Cocoa tree (cocoa merchant)	Plantain	Coconut tree (Number of nuts)*
0 (planting)	0	0	0
1	0	3 000	0
2	20	4 500	0
3	100	500	0
4	700	0	0
5	900	0	0
6	1 000	0	1 000
7	1 000	0	2 000
8	1 000	0	4 000
9	1 000	0	8 500
10	1 000	0	10 000
11	1 000	0	11 000
12	1 000	0	12 500
13	1 000	0	13 500
14	1 000	0	13 500
15 and beyond	1 000	0	13 500

*These productions are made by taking into account the optimum density for each plant.*

*(\*) The production of coconut trees is expressed in number of nuts / hectare.*



## Estimated operating account

### Plantations derived from cocoa and palm tree selected plant material

Description	Years															
	0	1	2	3	4	5	6	7	8	9	10	11	12	13	14	15
	<b>Yields (Kg/ha)</b>															
Groundnut	1 500	1000														
Maize	3 500	3000	1 000													
Plantain		3000	4 500	500												
Cocoa			30	100	300	600	700	800	800	800	800	800	800	800	800	800
Oil palm					3 000	4 000	6 000	8 000	10 000	11 000	12 000	13 000	13 000	13 000	13 000	13 000
	<b>Products</b>															
Groundnut	500 000	400 000														
Maize	455 000	390 000	200 000													
Plantain		480 000	675 000	75 000												
Cocoa			36 000	120 000	360 000	720 000	840 000	960 000	960 000	960 000	960 000	960 000	960 000	960 000	960 000	960 000
Palm oil					270 000	360 000	540 000	720 000	900 000	990 000	1080 000	1 117 000	1 117 000	1 117 000	1 117 000	1 117 000
<b>Total products</b>	955 000	1 270 000	911 000	195 000	630 000	1 080 000	1 380 000	1 680 000	1 860 000	1 950 000	2 040 000	2 130 000	2 130 000	2 130 000	2 130 000	2 130 000
	<b>Liabilities/depreciation</b>															
Annuites	121300	121 300	121 300	121 300	57 000	104 000	104 000	104 000	104 000	104 000	104 000	104 000	104 000	104 000	104 000	104 000
Inputs/ material	145 000	209 000	153 000	119 000	342 000	280 000	280 000	270 000	270 000	270 000	270 000	270 000	270 000	270 000	270 000	270 000
Labour	80 000	70 000	45 000	75 000	90 000	120 000	130 000	140 000	150 000	160 000	175 000	175 000	175 000	175 000	175 000	175 000
Total Liabilities	346 300	400 300	318 300	315 300	489 000	504 000	514 000	514 000	524 000	534 000	549 000	549 000	549 000	549 000	549 000	549 000
<b>Net margins</b>	608 700	869 700	372 700	-115 300	141 000	524 000	866 000	1 166 000	1 336 000	1 416 000	1 491 000	1 581 000	1 581 000	1 581 000	1 581 000	1 581 000

Average prices (Francs cfa/kg): Groundnut : 400 ; maize : 130 ; plantain : 150 ; cocoa : 1200 ; palm oil : 500F/litre.

The inputs are made up of chemicals (fertilizers, pesticides, etc.) and various equipments (cutlasses, files, knapsack sprayer, mist blower, etc.). The high value of liabilities as observed in year 0 and in year 1 is due to the fact that over these two years the farmer spends money for fertilizers (NPK20 10 10, and urea) necessary for producing maize. The serrate evolution of liabilities value is explained by the fact that every 5 years from the 5th year, the farmer renews his spraying equipment (mist blower).



## Estimated operating account

Plantations derived from hybrid cocoa seeds and from mass selected coconut plant material

Description	Years															
	0	1	2	3	4	5	6	7	8	9	10	11	12	13	14	15
	<b>Yields (kg/ha)</b>															
Groundnut	1 250	1000														
Maize	3 500	3000	1 000													
Plantain	3000	4 500	500													
Cocoa		30	100	300	600	700	800	800	800	800	800	800	800	800	800	800
Coconut(*)						1 000	2 000	4 000	8 500	10 000	11 000	12 500	13 500	13 500	13 500	13 500
	<b>Products</b>															
Groundnut	500 000	400 000														
Maize	455 000	390 000	130 000													
Plantain		480 000	720 000	80 000												
Cocoa		36 000	120 000	360 000	720 000	840 000	960 000	960 000	960 000	960 000	960 000	960 000	960 000	960 000	960 000	960 000
Coconut						75 000	150 000	300 000	637 500	750 000	825 000	937 500	1 012 500	1 012 500	1 012 500	1 012 500
<b>Total products</b>	955 000	1 270 000	886 000	200 000	360 000	720 000	915 000	1 110 000	1 260 000	1 597 500	1 710 000	1 785 000	1 897 500	1 972 500	1 972 500	1 972 500
	<b>Liabilities/depreciation</b>															
Annuities	121300	121 300	121 300	121 300	57 000	104 000	104 000	104 000	104 000	104 000	104 000	104 000	104 000	104 000	104 000	104 000
Inputs/material	144000	204 000	116 000	226 000	368 000	280 000	270 000	270 000	270 000	270 000	270 000	270 000	270 000	270 000	270 000	270 000
Labour	80 000	77 000	52 000	40 000	56 000	66 000	90 000	90 000	90 000	95 000	98 000	102 000	105 000	112 000	115 000	120 000
Total Liabilities	345300	402 300	289 300	387 300	481 000	450 000	474 000	464 000	464 000	469000	472 000	476 000	479 000	486 000	489 000	494 000
<b>Net margins</b>	609 700	867 700	596 700	-187 300	-121 000	270 000	441 000	646 000	796 000	1 125 500	1 238 000	1 309 000	1 418 000	1 486 000	1 483 000	1 478 500

Average prices (francs cfa/kg) : Groundnut : 400 ; maize : 130 ; plantain : 150 ; cocoa : 1200 ; coconut 75 F/ht.

(\*Yield : nuts/hectare

The inputs are made up of chemicals (fertilizers, pesticides, etc.) and various equipments (cutlasses, files, knapsack sprayer, mist blower, etc.). The high value of liabilities as observed in year 0 and in year 1 is due to the fact that over these two years the farmer spends money for fertilizers (NPK20 10 10, and urea) necessary for producing maize. The serrate evolution of liabilities value is explained by the fact that every 5 years from the 5th year, the farmer renews his spraying equipment (mist blower).



## Planting layout

### Cocoa - Oil palm intercropping

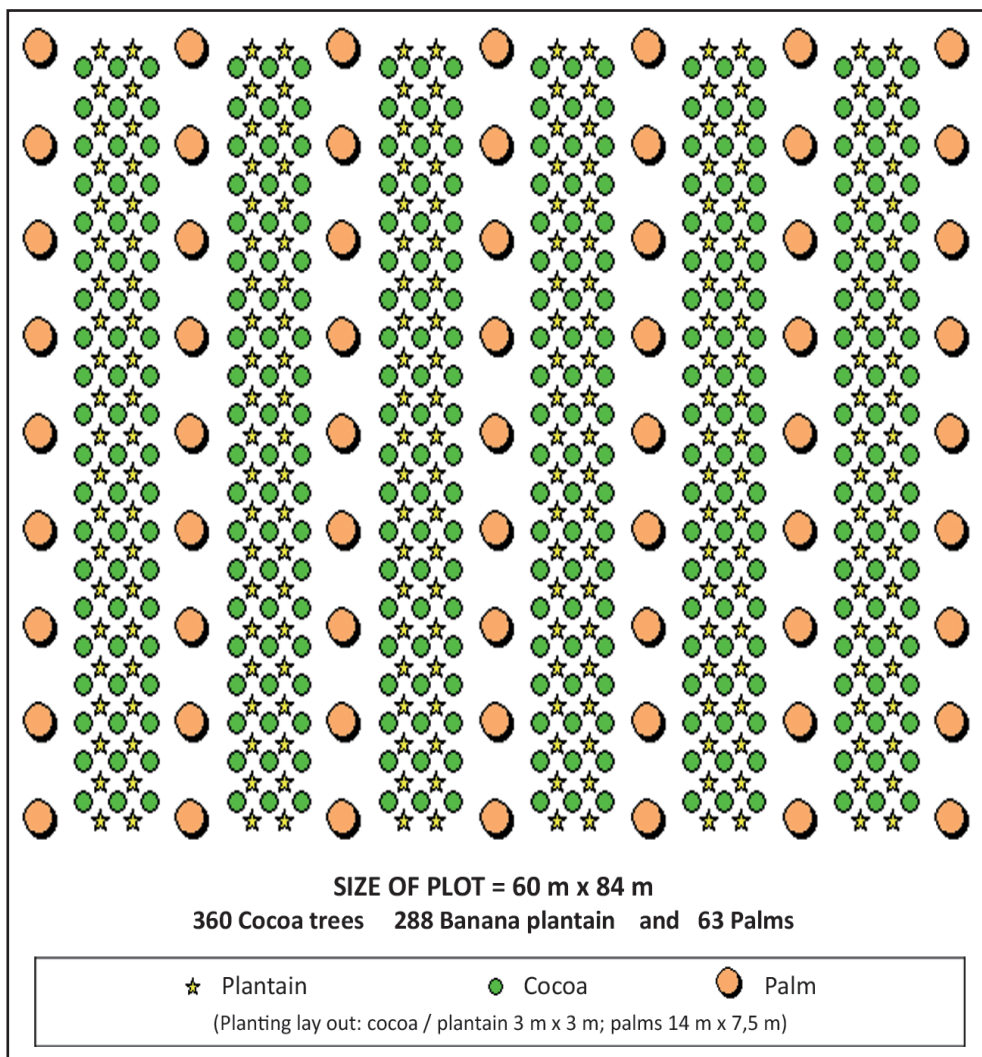

## Cocoa - Coconut trees intercropping

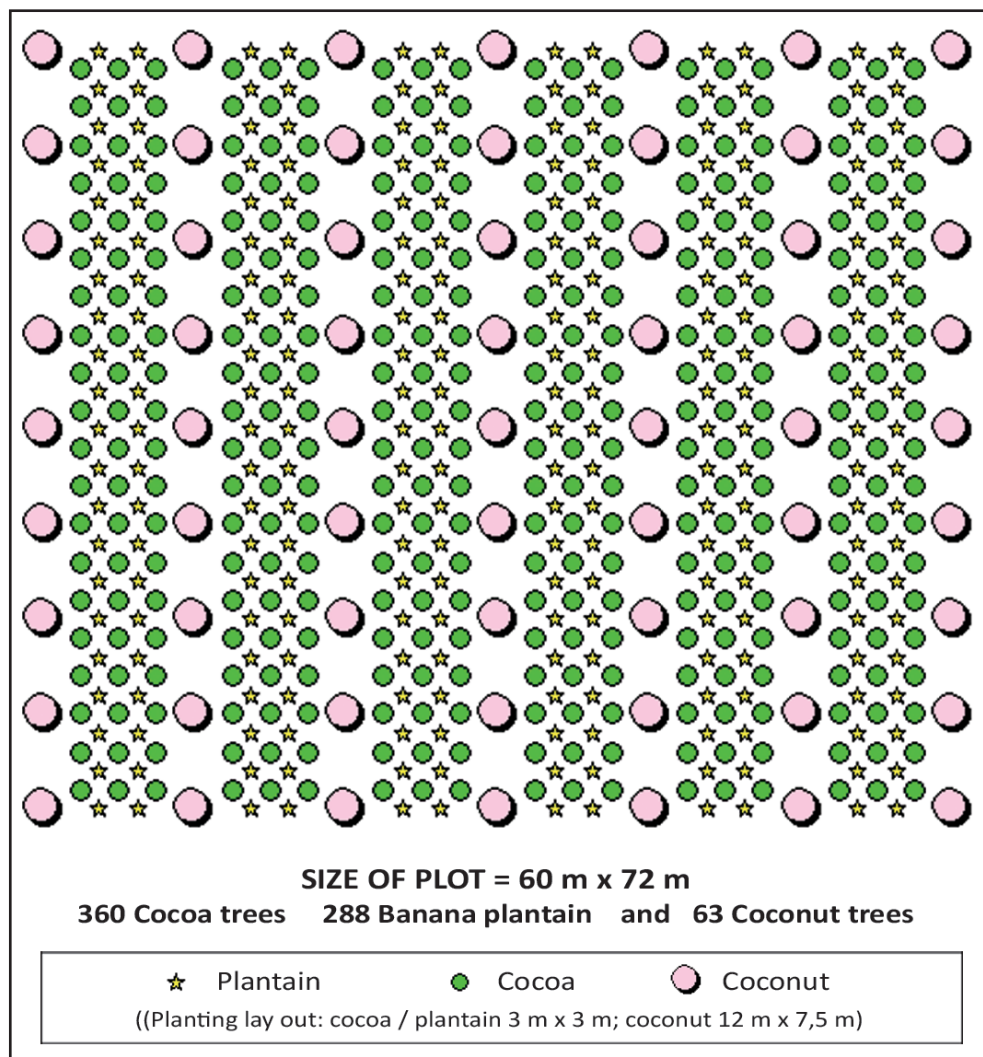



# Bibliography

Amoah F.M., Nuertey B.N., Baidoo-addo K., Opong F.K., Osei-bonsu K. and T.B.O. Asamoah 1995. Underplanting oil palm with cocoa in Ghana. *Agroforestry Systems* 30, p. 289-299.

Asare, R. (2005). Cocoa agroforests in West Africa: A look at activities on preferred trees in the farming systems. C. STCP: 77.

Barett C.B., Bezuneh M., Aboud A., 2001. Income diversification, poverty traps and policy shocks in Côte d'Ivoire and Kenya ; *Food policy* 26, p. 367-384.

Bonneaux X., Sugariato J., 1999. Cultures intercalaires de jeunes cocotiers hybrides en zone climatique marginale, *Plantation, Recherche, Développement*, vol. 6 (1), p.13-30.

Boussard B., 1980. Cultures intercalaires du caféier et du cacaoyer. *Café, Cacao, Thé*, vol., 24, n°1, p. 72-77.

Braconnier S., Chipungahelo G., Margate R.Z., Kleih U.1998. Les cultures associées avec le cocotier : modèle de fonctionnement et analyse économique, *Plantation, Recherche, Développement*, vol. 5 (4), p. 246-260.

Dufumier, M., 2006, Diversité des exploitations agricoles et pluriactivité des agriculteurs dans le Tiers Monde, *Cahiers d'études et de recherches francophones / Agricultures*. Volume 15, Numéro 6 p. 584-588.

Kuate J., Bella M., Damasse F., Kouodikong L., Atanga S., David O., Parrot L. 2006. Enquête sur les cultures fruitières dans les exploitations familiales agricoles en zone humide du Cameroun, *Fruits*, vol. 61 (6).

Egbe N.E., Adenikinju S.A. 1990. Effet de cultures intercalaires sur le rendement potentiel du cacaoyer dans le Sud-ouest du Nigeria. *Café, Cacao, Thé*,(Paris) vol. .XXXIV, n° 4, p. 195-202.

Lachenaud P., 1987. L'association cacaoyer-bananier plantain. Etude de dispositifs, *Café, Cacao, Thé*,(Paris) vol. .31, n° 3, juil-sept 1964, p. 173-202.

Losch B., Fusillier J.L.; Dupraz P.O. et Njoya J. 1991. Stratégies des producteurs en zone caféière et cacaoyère du Cameroun : quelles adaptations à la crise ? Collection DSA n° 12. DSA – CIRAD. Montpellier. 252 pp. Malézieux E., et

Moustier P. 2006, La diversification dans les agricultures du Sud : à la croisée de logiques d'environnement et de marché, II Niveaux d'organisation, méthodes d'analyse et outils de recherche, Cahiers d'études et de recherches francophones / Agricultures. Volume 15, Numéro 6.

Mertz O., Wadley R., L., Christensen A.E. 2005. Local land use strategies in globalizing world: Subsistence farming, cash crops and income diversification; *Agricultural systems* 85, p. 209 – 215.

Niehof A. 2004, The significance of diversification for rural livelihood systems, *Food policy* 29, p. 321-338.

Bonsu K., Opoku-Ameyax K., Amoah F.M. and Oppong F.K. 2002. Cacao-coconut intercropping in Ghana: agronomic and economic perspectives? *Agroforestry Systems* 55 (1), p. 1-8.

Sonwa D.J. 2004. Biomass management and diversification within cocoa agroforests in the humid forest zone of Southern Cameroon. PHD thesis, Université de Bonn, 112 pp.

Temple L., Minkoua Nzié J.R., David, O. 2007, Diversification des systèmes de cultures dans les exploitations cacaoyères au Cameroun et demande d'innovation technique, In *Exploitations agricoles familiales en Afrique de l'Ouest et du Centre*, CTA, Quae 303-311.

Mossu, G., (1990) *Le cacaoyer*. Le technicien d'agriculture tropicale, Maisonneuve et Larose. p. 90-110.



# Intercropping COCOA with OIL PALM or COCONUT



INNOVATIVE SYSTEMS IN COCOA CULTIVATION  
*Setting up a new plot on fallows or savannah areas*

Louis Dreyfus  
Commodities

